



USER MANUAL LDP-1000/2000 CW and Pulsed Laser Diode Driver Power Supplies



Your distributor:

The distributor information is presented in a light gray rectangular box. On the left side, there is a graphic consisting of a blue 3D pyramid and an orange 3D pyramid, both with white outlines. To the right of the graphic is the "Schulz Electronic" logo, which includes a blue triangle above the word "Schulz" and an orange triangle above the word "Electronic". Below the logo, the following contact information is listed:

Schulz-Electronic GmbH
Dr.-Rudolf-Eberle-Straße 2
D-76534 Baden-Baden
Fon + 49.7223.9636.0
Fax + 49.7223.9636.90
vertrieb@schulz-electronic.de
www.schulz-electronic.de

Table of Contents

1. Description of LDP Laser Diode Driver Series.....	3
2. Explanation of Symbols.....	4
3. LDP Diode Drivers - Theory of Operation.....	5
4. LDP Series Specifications	7
5. LDP-1000/2000 Interface	9
6. Installation and Operation of LDP Diode Drivers.....	10
7. Product Limited Warranty	16
8. Service	17

Tables and Figures

Table 1, LDP Models	7
Table 2, LDP Interface.....	9
Table 3, LDP AC Input Power Requirements	12
Figure 1, LDP Block Diagram	6
Figure 2, LDP Pulse Width Peak Output Power.....	8
Figure 3, Response of Iout to ENABLE signal.....	11
Figure 4, Redundant Safety Relays (optional).....	13
Figure 5, LDP Outline Drawing.....	15

1. Description of LDP Laser Diode Driver Series

The LDP Series is Lumina Power's new high power laser diode drivers capable of 10 kW peak power pulse operation and a maximum of 2000 Watts of continuous (CW) operation.

The LDP power supply is a programmable current source and delivers constant current based on the input program signal voltage, $I_{\text{program}(+)}$. All units are configured with a maximum current and maximum voltage capability, depending on the user's requirements. LDP power supplies will deliver current, as programmed, into any load, providing the voltage requirements of that load do not exceed the maximum rated voltage of the unit. When the required compliance voltage is higher than the maximum rated output voltage of the unit, the unit will limit output current and will shut down when the voltage reaches 105% of the rated voltage.

The LDP series model designations indicate the supply's continuous average power level, then maximum output current, followed by the maximum output voltage. For example, model LDP-1000/2000-100-100 is a 1000 Watt average power in pulse mode and a maximum of 2000 Watt continuous output, 100 Ampere peak current, 100 Volt maximum output unit capable of delivering 10kW peak power pulses.

2.Explanation of Symbols



Hazard: This equipment produces high voltages which can be fatal. Only service personnel of Lumina Power, Inc. are qualified to service this equipment.



High Voltage Present. This power supply produces lethal high voltages. Only service personnel of Lumina Power, Inc., are qualified to service this equipment. Only qualified service personnel are permitted to install this power supply.



Chassis Ground: This symbol where the protective earth ground connection is located.

3.LDP Diode Drivers - Theory of Operation

(Refer to Figure 1)

The LDP laser diode drivers are designed specifically for OEM high power CW and pulsed laser diode systems. OEM power supplies for the laser diode industry have the following requirements:

- Safe laser diode operation
- Broad range of control of output current
- Safe rise/fall times
- Small size
- Power factor correction to conform with CE requirements
- Low conducted electromagnetic emissions
- Low leakage for medical applications

Referring to Figure 1, LDP Block Diagram, the following is a brief description of operation.

AC Input Power Circuitry

AC input power is processed through a line filter to reduce the conducted EMI to an acceptable level. The LDP line filter has minimum capacitance to ground to minimize leakage currents. An Earth Ground stud is provided near the AC input terminals and must be connected to the system ground.

Power Factor Correction Boost Inverter

The rectified input power is next applied to a power factor correction (PFC) boost inverter. This inverter boosts the input voltage to 400VDC. In the process of boosting the input AC voltage, the input AC current is adjusted so that it is always in phase with the input AC voltage. Without this power factor correction circuit, the AC input current would be delivered to the power supply in high amplitude, narrow spikes, having a high harmonic content. With power factor correction, the non-50/60 Hz harmonics are reduced to near zero. Only the fundamental frequency is now used to deliver power so the efficiency of the power supply is considerably improved. This is superior to traditional power factor correction circuits in drastically reducing conducted line noise. Note: Efficiency is a function of the output compliance voltage.

Lumina Power employs a proprietary soft-switching, zero current and voltage transition technique in the boost inverter which produces minimum switching noise, reduces switching losses, and results in a smaller heat sink associated with the power factor circuit.

The PFC capacitor stores the energy needed to deliver the high peak power pulses.

Zero Voltage Switching (ZVS) Inverter

The ZVS inverter and the output transformer are used to step the 400VDC bus down to the appropriate output value. The ZVS inverter is the most modern high frequency/low loss/low noise topology utilized in power electronics today. Instead of running the inverter in a traditional PWM mode, the inverter is run in a phase shift mode. With the appropriate

output inductor and the appropriate capacitance across each switching device, in this case MOSFETS, there are virtually no switching losses in the inverter. The only losses in the devices are I^2R losses associated with the Drain/Source resistance of the MOSFETS. Therefore, the ZVS inverter also contributes to reduced losses, reduced EMI noise and a reduction in overall system heat sink requirements.

Output Circuit

The output filter is a two stage RC filter designed to keep ripple and output noise very low.

Control Circuit

The control circuit handles all the responsibilities associated with safe operation of the laser diode. Controlled rise and fall times, as well as tight current regulation, overvoltage and over power protection are controlled and monitored in the control circuit.

Auxiliary Power

All internal power supply requirements as well as the external +/-15V and +5V power supplies are derived from the power factor control boost inductor. All auxiliary power supplies are regulated by standard linear regulators.

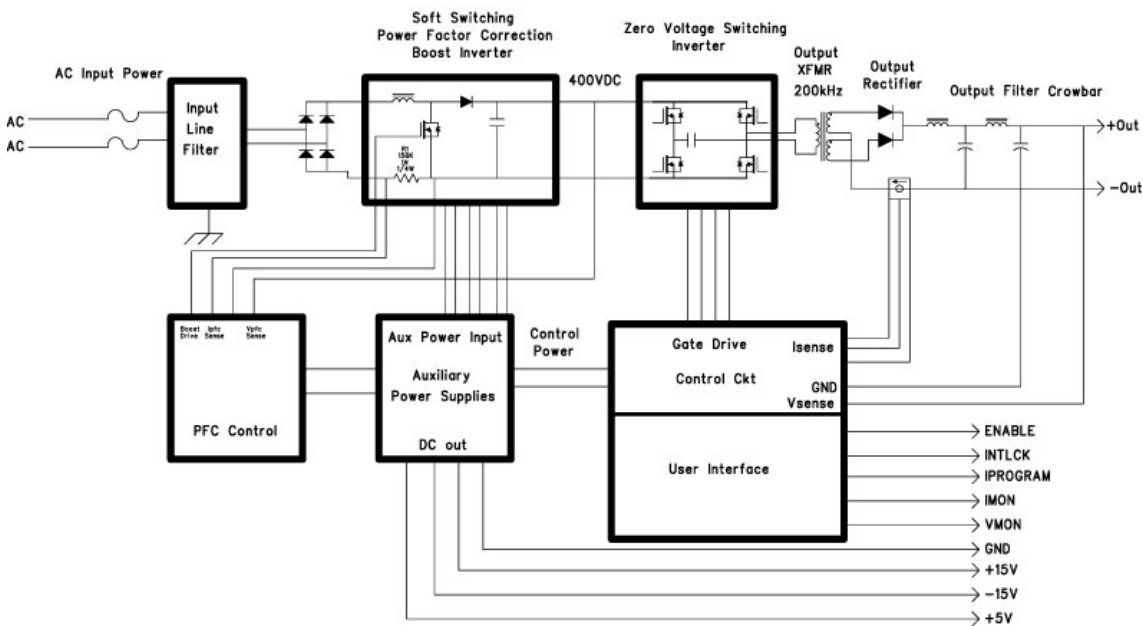

Figure 1, LDP Block Diagram

4.LDP Series Specifications

Table 1, LDP Models

LDP model numbering indicates: XX is $I_{out_{max}}$, YY is $V_{out_{max}}$,
and $XX * YY$ cannot exceed $P_{out_{max}}$

Model	$P_{out_{max}}$	$I_{out_{max}}$	Input Voltage	Size (L x W x H)
LDP-1000-XX-YY- (S or L)	1000W Pulsed 1000W CW	400 Amp	100-240VAC $\pm 10\%$	9.98" x 8.95" x 4.75"
LDP-2000-XX-YY-(S or L)	1000W Pulsed 2000W CW		200-240VAC $\pm 10\%$	25.3 x 22.7 x 12.1 cm
Auxiliary Outputs: +15V @0.2A -15V @0.2A				
Maximum output compliance voltage : 100V (For higher voltages contact Lumina Power)				
Options: RS-232, Din Standard Safety Relay. Consult Factory or local rep. Custom configurations available in volume.				

Input

Voltage	See table above
Power Factor	>.98
Efficiency	>87% (when $V_{out_{max}} >15V$)

Interface

	(see section 5 LDP-1000/2000 Interface for details)
Connector	15 Pin "D" Sub Female
Current Program	0-10V for 0-Max Current
Current Monitor	0-10V for 0-Max Current
Voltage Monitor	0-10V for 0-Max Voltage

Performance

Pulse Width Range	30 μ s to CW
Max Pulse Width at Max Current	3ms for the -S version 30ms for the -L version
Rise time	< 25ms using pin 1 enable
Rise/Fall Time	$\leq 10\mu$ sec (10% to 90% Full Current) when pulsing pin 8
Current Regulation	<0.5% of maximum output current
Current Ripple	<0.5% of maximum output current
Current Overshoot	<1% of maximum output current
Power Limit	Limited to maximum power with power fold-back option

Environment

Operating Temp	0 to 40 °C
Storage	-20 to 85 °C
Humidity	0 to 90% non-condensing
Cooling	Forced air
Altitude and Pressure	2000 meters maximum, 80 to 103 kPa

Dimensions

Outline Dimensions	Please see Figure 5, LDP Outline Drawing outline drawing 9.98 inch length, 8.95 inch wide, 4.75 inch high
--------------------	--

Mounting 25.3 cm length, 22.7 cm wide, 12.1 cm high
 9.59 by 5.0 inch
 24.4 by 12.7 cm

Safety and Regulatory

Leakage Current <450uA
 Medical Safety UL60601-1, IEC 60601-1, EN 60601-1, 2nd, 3rd Edition, CAN/CSA C22.2 No. 601.1-M90
 EMI FCC 47 CFR Class A Emissions
 EN55011:1998 Group 1 Class A Emissions
 EN61000-3-2 Limits for harmonic current emissions
 EN 610000303 Flicker
 EN60601-1-2 4th Edition Electromagnetic emissions and immunity for medical equipment

Peak Power Derating Curve

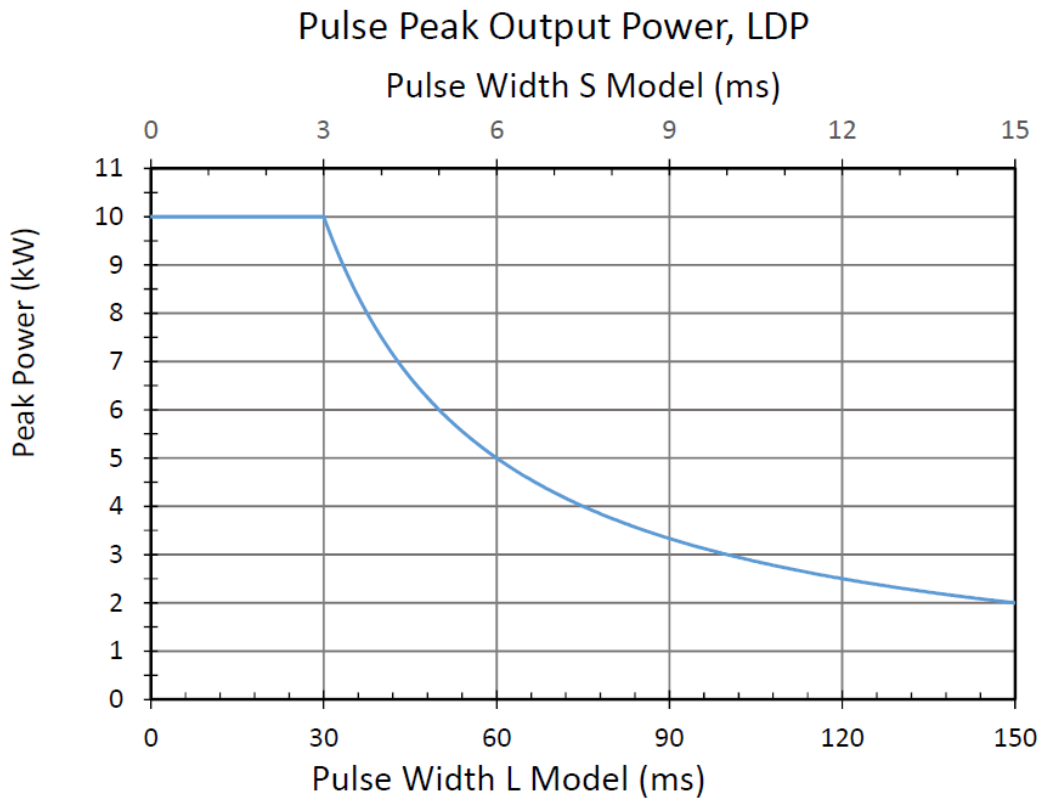

Figure 2, LDP Pulse Width Peak Output Power

5.LDP-1000/2000 Interface

Connector Type 15 pin D-sub Female
Refer to Figure 2, Interface Schematic

Table 2, LDP Interface

Pin #	Pin Name	Functional Level	Description
1	Enable (input)	High = RUN =+5V to +15V Low = OFF = 0V	The Enable function turns the output section of the power supply ON and OFF. When the power supply is enabled, current is delivered to load as programmed via Iprogram(+) , Pin 7, if the the Interlock , pin 3 is connected to GND . Rise times resulting from Enable are approximately 25msec. Enable signal must be inserted AFTER AC power has been applied and fans are running. The power supply starts up OFF disregarding the state of the Enable signal.
2	Fault (output)	Low= Fault (power supply is disabled)	When a fault is detected the power supply is disabled and this output goes low.
3	Interlock (input)	Open = OFF Connect to GND = RUN	The Interlock function must be connected to GND , <0.2V, for output current to be delivered. It can be used for external interlock functions such as door or overtemp switches.
4,9	GND		Interface return
5	*Vout Monitor: (output)	0 – 10V ⁽¹⁾ = 0 – Vout _{max} ⁽²⁾	The output voltage of the supply can be monitored by Vout Monitor . See Note 2.
6	Iout Monitor (output)	0 – 10V ⁽¹⁾ = 0 – Iout _{max}	The output current of the supply can be monitored by Iout Monitor .
7	Iprogram(+) (input)	0 – 10V ⁽¹⁾ = 0 – Iout _{max}	The power supply output current is set by applying a 0-10V analog signal to Iprogram(+) .
8	Pulse	TTL or CMOS High	Allows output to be pulsed for fast rise time. Default is Low or off without connection to pin 8. Pull pin 8 high for CW or pulsing.
10, 11, 15	No Connect		Not used, do not connect to these pins.
12	-15V @0.2A (output)		Auxiliary -15V power supply for user. Up to 0.2A output current available.
13,14	+15V @0.2A (output)		Auxiliary +15V power supply for user. Up to 0.2A output current available.

Notes:

1. Analog voltage range of 0-5V available per customer request.
2. If the maximum compliance voltage is less than 10V, the **Vout Monitor** will read the output voltage directly.

6. Installation and Operation of LDP Diode Drivers

IMPORTANT INSTALLATION NOTES

- LDP diode drivers are air cooled by internal fans. Do not restrict air flow near the input or output air vents of the power supply. If the unit overheats due to restricted air flow, it will shut down and remain off until the unit has cooled to a safe operating temperature.
- **There must be at least 2 inches of clearance on each end of the power supply for air intake and exhaust.**
- LDP units should be mounted in systems using 8-32 (or M4) bolts to secure the mounting flanges to mounting plate.

SAFETY WARNING

Because LDP units are designed for OEM applications, the user must connect AC mains input power to the power supply. Any input AC voltage must be considered extremely dangerous, and as such, care must be taken when connecting the AC mains input power to the unit.

1. **CONNECTING TO DIODE LASER** Connect diode laser load to the output terminals using the supplied multi-twisted cable. To minimize wiring inductance and avoid I^2R losses it is a good practice to keep connections between the diode laser and power supply as short as possible. Wire lengths should be less than 1 meter. Consult factory for recommendation on specifying longer lengths.
2. **INTERFACE CONNECTION** Connect user system to 15 pin D-sub connector. (Although the user interface is typically designed by the user, Lumina Power can provide any assistance necessary to modify interface program and monitor levels) See Table 2 for description of the LDP Interface.

IMPORTANT NOTE

Make sure when connecting to the interface that the current program setting, **Iprogram(+)**, is set no higher than the value required for operation. When AC power is applied and system is **Enabled**, output current will rise to this program value

3. **INTERFACE INFORMATION BEFORE APPLYING AC POWER:** The unit may be programmed for output current via Pin-7, the **Iprogram** function. But there are four interface control signals which must be properly set before the output will deliver current as programmed by **Iprogram**.

- a. **Interlock:** Pin 3, the **Interlock**, must be grounded via Pins 4, 9 or 15 in order for the output to deliver current.
- b. **Enable:** Pin 1, the **Enable** signal is a 5V to 15V signal used to turn the output section on. The **Enable** circuitry incorporates a soft start function which ensures rise times of approximately 15 to 25msec.

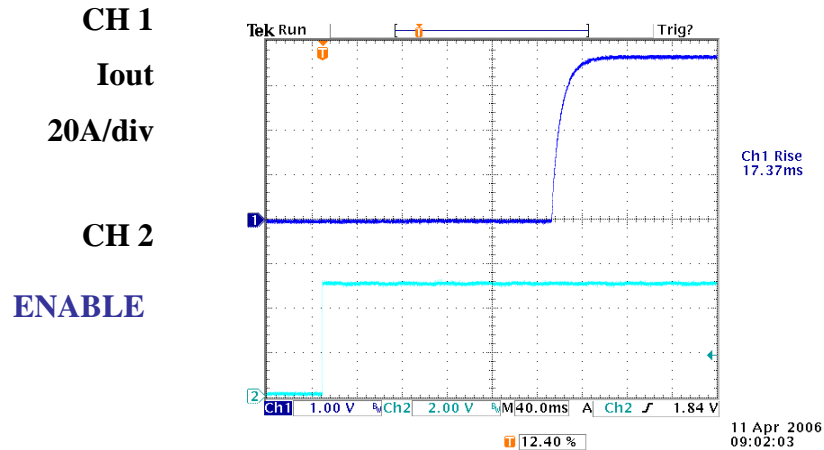

Figure 3, Response of Iout to ENABLE signal

- c. **Iprogram:** Pin 7. A 0-10V signal results in 0 to $I_{out_{max}}$, as long as the rated compliance voltage of the driver is not exceeded.
- d. **Pulse:** Pin 8. A high voltage, TTL or CMOS, greater than 4 Vdc is required to turn on the output current.

NOTE: Enable (pin1) must be OFF (pulled to GND) when applying AC current. Power supply will not output current if AC power is applied with the enable Pin 1 high until the input is toggled low and then voltage is reapplied.

4. Operating the LDP

AC INPUT POWER CONNECTION

Connect AC power connections to power supply input power terminals as follows (refer to Figure 3.)

- Neutral wire (16AWG) connected to the right contact of the AC input terminal (labeled N).
- Line wire (16AWG) connected to the left contact of the AC terminal block.
- Ground wire must be crimped to a # 8 (metric M4) ring-lug and connected to the ground stud.

IMPORTANT APPLICATION NOTE REGARDING AC INPUT POWER

AC Input wires should be at least #16 AWG, rated for at least 300V and 105 °C.

IMPORTANT SYSTEM NOTE ON AC INPUT POWER

LDP units are fused on both input lines. It does not matter which of the two AC inputs are designated Line or Neutral.

AC input power requirements for LDP models are as follows:

Table 3, LDP AC Input Power Requirements

MODEL	INPUT POWER
LDP-1000/2000-XX-XX	100-240 VAC, 50/60 Hz, 10A @115VAC, 10,5A @ 220VAC

Note: The LDP laser diode drivers offer efficiencies >87% when specified with output voltages greater than 15V. Efficiency is lower at lower compliance voltages.

- INTERFACE SETTINGS:** Make sure **INTERLOCK**, Pin 3, is connected to GND.
- APPLY INPUT AC POWER** Turn ON AC power. After a few seconds the power supply fans should begin to run.
- PROGRAMMING OUTPUT CURRENT** Program LDP power supply for desired output current. A 0-10V signal applied to **Iprogram**, Pin 7, will program the LDP diode driver for 0 to maximum rated output current.
- ENABLE OUTPUT** Apply +5V to +15V to **ENABLE**, Pin 1. The LDP will deliver output current as programmed.

IMPORTANT APPLICATION NOTE

When the power supply is enabled using the ENABLE signal, internal soft start functions limit the rise time of the output current to approximately 20msec. Use Pulse pin (8) for fast rise time pulsed applications

5. Monitoring LDP output and performance:

- a. **Current Monitor** Power supply output current can be monitored via pin 6, **Iout Monitor**. A 0-10V signal will represent the output current from 0 to maximum rated output current.
- b. **Voltage Monitor** Power supply output voltage can be monitored via pin 5, **Vout Monitor**. A 0-10V signal will represent the output voltage from 0-maximum rated output voltage.

Options:

If the part number of your laser diode driver includes the following options please note:

Suffix: “FR”: The Fast Rise Time option reduces the rise time of the power supply for better pulse performance. This exact rise time is an agreed upon specification that is included on the test data sheet shipped with every power supply. Contact Customer Service if you need a replacement Test Data Sheet.

Suffix “SR” Safety Relay Option

The new LDP series Laser Diode Drivers can be specified to include the optional Dual Relay board and interface that allows the laser designer the ability to monitor the power supplies performance and signal the user if a fault occurs. This redundant safety feature complies with the ISO-DIN 13849-1-2008 safety standard at the highest level E and can be used to eliminate the costly safety shutter in many laser systems.

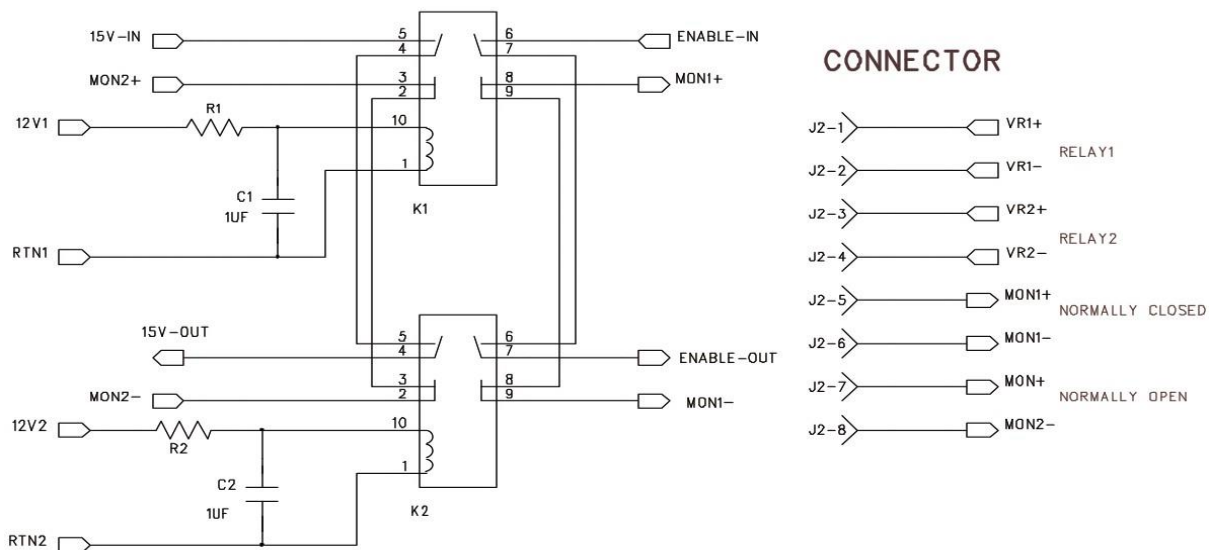

Figure 4, Redundant Safety Relays (optional)

Relay K1 & K2 are 2 identical relays in series to control the VCC and Enable signals of the power supply. Both signals have to be active for the power supply to run. When both relays are energized, all contacts will be directed to the energized positions.

There are also 2 monitor signals for these relays to ensure that they are working properly. One is normally closed and one is normally open. If the power supply is functioning correctly and the relays are energized, the Normally Closed will be open and the Normally Open will be closed. This indicates the relays are good and the power supply will operate normally.

Both relays are forcibly latched and thus if one contact is stuck, the other contacts will be forced to the position of the faulty contact. If one or both relays are faulty and stuck Closed or Open, either the Normally Closed will not be Closed or the Normally Open will not Close. The host system should use these monitor signals to determine if the relays are good or bad.

7. Product Limited Warranty

Lumina Power, Inc., as Seller, warrants that each Product sold by it is free of defects in materials and workmanship. Duration of warranty is as follows:

- a. All Chassis enclosed products are covered for twenty four (24) months from date of shipment. Products included but are not limited to the following product families: LDD, LDP, LDDHC, LDY, LDYHC, LDQCW, XLB (excluding XLB-300), MLB, CCPF and CCHP. Custom fully enclosed products may be covered for the same 24 months. Please consult factory for specific terms.
- b. All Open Frame products are covered for 12 months from date of shipment. Open frame power supplies are defined as any product that is not enclosed in a metal or plastic enclosure. Products included but are not limited to the following product families: LDPC, LDQPC, XLB-300 and any open frame custom products.
- c. All products returned for repair are covered for a period of 6 month or the balance of the original warranty, whichever is longer.

Warranty is not transferable to parties outside of original Buyer's corporate or educational organization. Seller will have sole discretion in making determination of validity of warranty if the Product is transferred to a different user group than the original Buyer.

Normal wear and tear and items expendable in normal use are not covered by this warranty. All warranty repair or replacement of parts shall be limited to Product malfunctions, which, in the sole opinion of Seller, are due or traceable to defects in original materials or workmanship. Such determination will be made when the Product is returned to the Seller's factory, transportation prepaid by the Buyer, within the warranty period.

All obligations under this warranty shall cease immediately in the event of abuse, accident, alteration, misuse, or neglect of the Product. Use and service of the Product in a manner not in accordance with the Owner's Manual (if furnished) will likewise cause all obligations under this warranty to cease. Repaired or replacement parts are warranted only for the remaining unexpired portion of the original warranty period for the Product. After expiration of the applicable warranty period, Buyer shall be charged at the then current prices for parts, labor and transportation.

Seller has no responsibility under this warranty for the cost of any work (material, labor, and/or other expenses) performed by or incurred by Buyer or any third party for modification or repair of the Product unless specifically authorized in advance in writing by Seller.

Reasonable care must be used to avoid hazards. Seller expressly disclaims responsibility for loss or damage caused by use of its Products other than in accordance with proper operation procedures. Other than those expressly stated herein, there are no other warranties of any kind, expressed or implied, and specifically included but not by way of limitation are the implied warranties of fitness or merchantability for a particular purpose.

It is understood and agreed the seller's liability whether in contract, in tort, under any warranty, in negligence or otherwise shall not exceed the return of the amount of the purchase price paid by the purchaser and under no circumstance shall seller be liable for special, indirect, incidental or consequential damages. The price stated for the product is a consideration in limiting seller's liability. No action, regardless of form, arising out of the transactions of this agreement may be brought by purchaser more than one year after the cause of action has accrued.

Seller's maximum liability shall not exceed and buyer's remedy is limited to either (i) repair or replacement of the defective part of product, or at seller's option (ii) return of the product and refund of the purchase price, and such remedy shall be the buyer's entire and exclusive remedy.

8. Service

This unit contains no user serviceable parts. Service and repair should be performed only by qualified personnel from Lumina Power, Inc. For more information contact

Lumina Power, Inc.
26 Ward Hill Ave.,
Bradford, MA 01960
Ph: 978-241-8260
Fx: 978-241-8262

Email: sales@luminapower.com Web site: www.luminapower.com

Rev	ECO	Description	Doc Ctrl	Date	App
1	7620	Initial Release	MJ	11/10/2017	EK