

XLB Series Power Supply Application Notes

Introduction

The XLB series short arc lamp power supplies are designed to ignite and properly power Xenon short arc lamps ranging in power from 100 watts to over 6000 watts. These power supplies are easy to operate and will perform reliably for many years with virtually no maintenance if a few simple steps are followed. This document is a guide to proper installation and operation of these power supplies and should be used to assess the viability of the power supply and igniter in both new and upgrade applications.

Basic Operation (Refer to Figure 1, page 2)

AC Input Power Circuitry

AC input power is processed through a line filter to reduce the conducted EMI to an acceptable level. The XLB-1000/1500 line filter has minimum capacitance to ground to minimize leakage currents.

Power Factor Correction Boost Inverter

The rectified input power is next applied to a power factor boost inverter. This inverter boosts the input voltage to 400VDC. In the process of boosting the rectified input voltage, the input AC current is adjusted so that is always in phase with the input AC voltage. Without this power factor correction circuit, the AC input current would be delivered to the power supply in high amplitude, narrow spikes, having a high harmonic content. With power factor correction, the non- 50/60 Hz harmonics are reduced to near zero. Since only the fundamental frequency is now used to deliver power, the efficiency of the power supply is improved considerably. One problem with standard input power factor correction circuits is that a high frequency switching circuit is placed across the line in the input side of the traditional capacitor filter capacitor. This circuit results in substantial switching noise conducted to the line. Lumina Power employs a proprietary soft-switching boost inverter which produces minimum switching noise, reduces switching losses, and results in a smaller heat sink associated with the power factor circuit.

Zero Voltage Switching (ZVS) Inverter

The ZVS inverter and the output transformer are used to step the 400VDC bus down to the appropriate output value. The ZVS inverter is the most modern high frequency/low loss/low noise topology utilized in power electronics today. Instead of running the inverter in a traditional PWM mode, the inverter is run in a phase shift mode. With the appropriate output inductor and capacitance across each switching device - in this case MOSFETS - there are virtually no switching losses in the inverter. The only losses in the devices are I^2R losses associated with the Drain/Source resistance of the

MOSFETS. Therefore, the ZVS inverter also contributes to reduced losses, reduced EMI noise and a reduction in overall system heat sink requirements.

Output Circuit

The output filter is a single stage RC filter designed to minimize output ripple and noise.

Control Circuit

The control circuit handles all the responsibilities associated with safe operation of the Xenon lamp. Reliable lamp ignition as well as tight current regulation, overvoltage and over power protection are controlled and monitored in the control circuit.

Auxiliary Power

All internal power supply requirements as well as the external +15V power supply are derived from the power factor control boost inductor. The +15V auxiliary voltage is regulated by a standard linear regulator.

Lamp Igniter Module

The igniter module provides the 40kV pulse required to break down the Xenon gas and facilitate ignition. In standard configurations, the pulse is applied through the positive output to the lamp anode. Power to the module is provided by the main power supply chassis. Internal circuitry in the igniter module senses the presence of the high voltage arc and briefly disables operation in the main power supply chassis in order to minimize damage from high voltage noise.

Figure 1 Block Diagram

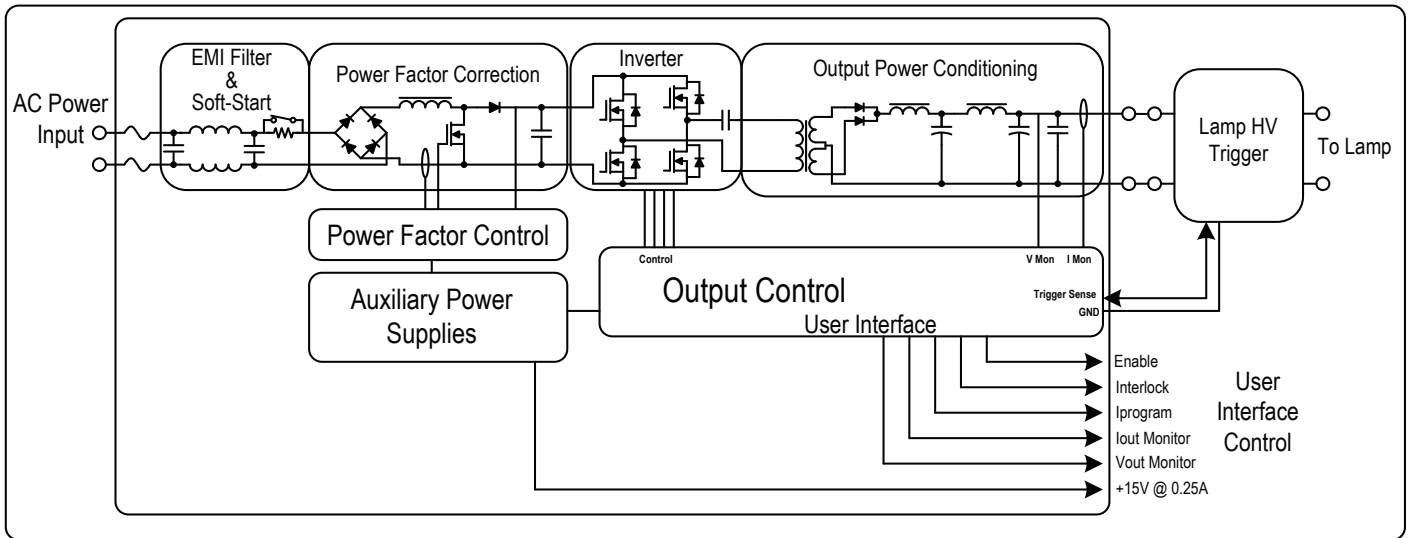

Xenon Lamps

Other than lasers, short arc lamps are the brightest manufactured sources of DC radiation. A large portion of their output is in the UV-VIS, which makes them useful for UV spectroscopy, UV photochemistry, solar simulation and other high intensity light applications. Xenon short arc lamps have a correlated color temperature close to that of the sun, ~5800 K. The arc region between the anode and the cathode is so small that for many purposes, these lamps are effectively point sources. These small, bright sources can produce high intensity collimated beams using condensing lens assemblies or be re-imaged onto fiber optic bundles. Power levels of 50 to 5000 Watts are typical but Xenon arc lamps can be built to power levels of 30kW.

Arc Lamp Basics

Fig. 2 shows the construction of typical arc lamps. The anode and the cathode are sealed in a clear quartz envelope. Quartz is used for mechanical and thermal durability. The type of quartz used depends on the desired ultraviolet output. Some lamps use high quality UV grade quartz to transmit output to below 200 nm. Others use doped quartz, which absorbs short wavelengths to minimize ozone generation and are referred to as ozone free lamps. The quartz bulb is carefully shaped to withstand the thermal gradients and shock inherent in running these lamps. The bulb has a small sealed-off tip used to evacuate air and fill with Xenon during construction.

Construction of Arc Lamps.

Anode and Cathode: The anode and cathode are made of tungsten. The tungsten used in the cathode is doped with materials such as thorium dioxide to enhance electron emission. The cathode is small and pointed to ensure that the tip reaches a high temperature for efficient electron emission. The anode is more massive to withstand the electron bombardment and efficiently dissipate the heat produced. The anode-cathode gap can be from 0.25 mm to several mm, depending on the lamp power rating.

Gas Fill: Lamps are filled with Xenon at several atmospheres pressure. When the lamps run, the internal pressure increases to 12 to 75 bar, depending on the lamp type. The high pressures demand special care in the handling and operation of these lamps.

Terminals: The two metal terminals at the ends of the lamp are for the electrical connections and mechanical support of the lamp. The terminals are connected to the electrodes by molybdenum foil strips inside the glass stem, or, for the higher current lamps, by tungsten rods.

Typical Xenon Arc Lamp

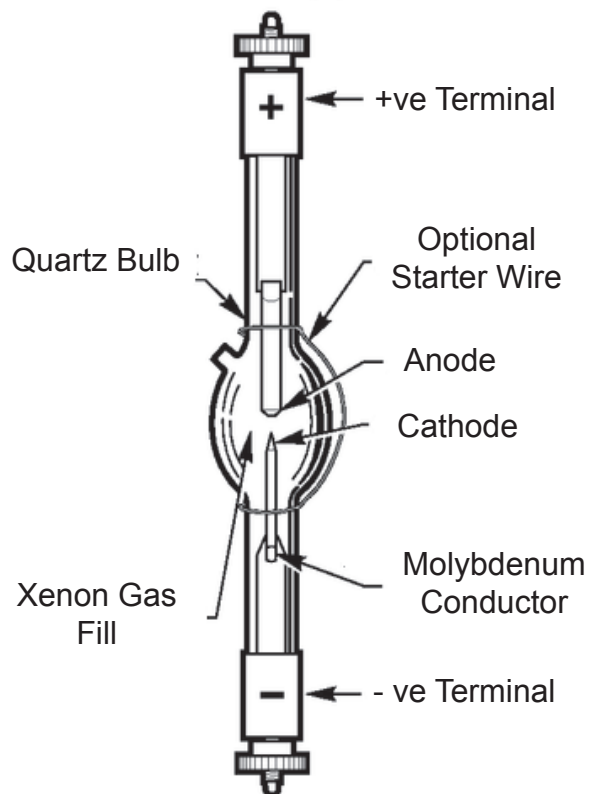

Figure 2

Cermax Lamps

Cermax lamps are compact ceramic xenon short-arc lamps. Combining an internal reflector, ceramic body and seal construction, Cermax lamps are a compact alternative to conventional quartz xenon lamps. Utilizing an integrated parabolic or ellipsoidal reflector, Cermax lamps produce a high intensity, collimated or focused output of light. Due to the xenon lamps broad color spectrum, the lamp is filtered to emit either visible, UV or IR light depending on application or usage. Standard Cermax lamps have operating power ranges from 75 to 2500 watts.

Lamp Stability

Arc instability or “arc wander” as it is called is a common phenomenon in arc lamps. These spacial variations in the arc are usually the result of convection currents in the lamp and/or arc migration on the electrodes. Over the years lamp manufacturers have worked to reduce the effect by improving the design and materials used in the electrodes. There has also been a lot of research into magnetic stabilization of the arc. These methods have improved the stability of the lamps but not completely eliminated the problem. In most cases the small variation in light output can be tolerated but for precise applications your lamp manufacturer should be able to assist you in selecting the best lamp for your program.

Older power supply designs with high amounts of AC ripple can also cause instability in the lamp’s light output. These low frequency (<120Hz) variations could be very noticeable and usually required additional filtering of the power supply’s output to stabilize the light. All XLB power supplies use advanced switch-mode designs that produce very small amounts (<0.5%) of ripple in the output at frequencies above 60kHz. that have no effect on the stability of the lamp.

Power Supply Installation

The XLB series power supplies are designed to accept a wide range of input voltages allowing these supplies to be installed anywhere in the world. The XLB-650 & 1000 accept 100 to 240VAC $\pm 10\%$ while the XLB-1500, 2500 & 3000 require 200 to 240VAC $\pm 10\%$. The XLB-5000 requires 3 phase current and can be set for 200 to 240VAC or 380 to 440VAC $\pm 10\%$. Proper input wire size should be used for proper operation and safety. For input cables that are under 6 feet long use the following wire sizes:

Model	Wire Size
XLB-650 (120VAC)	16 gauge
XLB-1000 (120VAC)	14 gauge
XLB-1500	14 gauge
XLB-2500	12 gauge
XLB-3000	12 gauge
XLB-5000	10 gauge



Any input AC voltage must be considered extremely dangerous. care must be taken when connecting AC input power to the unit.

Note: These wire sizes are for reference only. Please consult your local electrical codes for wire sizes.

Single phase XLB units are fused on both input lines. It does not matter which of the two AC inputs are designated Line or Neutral.

Mounting and Cooling

All XLB series power supplies require adequate airflow for proper cooling. These power supplies can be mounted horizontally using the mounting tabs on each side of the supply or vertically with the airflow exhaust aimed upward. It is essential that exhausted hot air from the power supply is directed out of the enclosure and is not allowed to recirculate back through the power supply.

Output Connections

Connecting the output of the power supply requires the use of the proper size wires equipped with terminals that are crimped and soldered to reduce heating at these points. These wires will be required to carry high current and should be as short as possible.

The following table offers guidelines on proper wire sizes for the output currents of the various models.

Output Wire Size Chart (Assuming 3 feet from power supply to the igniter)

Output Current	Wire Size
20 to 30 amps	12 gauge
30 to 50 amps	10 gauge
50 to 70 amps	8 gauge
70 to 100 amps	6 gauge
100 to 150 amps	4 gauge
150 to 200 amps	2 gauge



Terminals must be crimped and soldered to reduce heating at these points. Excessive heating of the terminations can damage the power supply and/or the igniter and is not covered under warranty.

The output terminals of the XLB power supplies are fitted with the following connectors or screw sizes.

Model	Connector
XLB-650	Molex connector
XLB-1000/1500	8-32 Screws
XLB-2500	1/4-20 Screws
XLB-3000	1/4-20 Screws
XLB-5000	1/4-20 Screws

The XLB-650 is equipped with a Molex # 42818-0212 connector. Mate and 24" cable supplied.

All other models require customer supplied cables.

Control Interface

All XLB power supplies share a common 15 pin Analog/TTL interface. For more detailed interface information please refer to the XLB Owners Manual.

Standard 15 Pin Interface (15 pin D-Sub, Female)

Pin #	Pin Name	Functional Voltage Level	Description
1	Lamp On/Off (input) (Note: 1)	High = RUN = +5V to +15V Low = OFF = 0V	The Lamp On/Off function is the control function which turns the lamp on and off. When the lamp is turned on, a trigger and boost sequence will ignite the lamp and deliver current as programmed via Iprogram, Pin 7.
3	Interlock (Input)	Open = OFF Connect to GND = RUN	The Interlock function can be connected to external interlock switches such as door or overtemp switches.
4,9, 15	GND		Interface Return
5	Vout Monitor (output)	0-10V = 0-Voutmax	The output voltage of the supply can be monitored by Vout Monitor. Note: See selection chart on page 2 for maximum output voltage setting per model.
6	Iout Monitor (output)	0-10V = 0-Ioutmax	The output current of the supply can be monitored by Iout Monitor.
7	Iprogram (input)	0-10V = 0-Ioutmax	The power supply output current is set by applying a 0-10V analog signal to Iprogram(+).
8	Lamp Status	High = lamp off = 15V Low = lamp on = 0V	The status of the lamp can be monitored using this pin
13,14	+15V (output)		Auxiliary 200mA

Pin 2 and 10: no connection

Igniter Module

The igniter module provides the high voltage pulse that creates a high potential from the cathode to the anode of the lamp forcing an arc to form between these electrodes. Once the electrical path is established the impedance of the lamp drops allowing current to flow. The XLB igniter operates automatically when the power supply is enabled (see interface information pg. 6). The Igniter is connected between the power supply and the lamp and is charged from the boost voltage generated by the power supply when enabled. Figure 3 is the wiring diagram for the power supply/igniter combination:

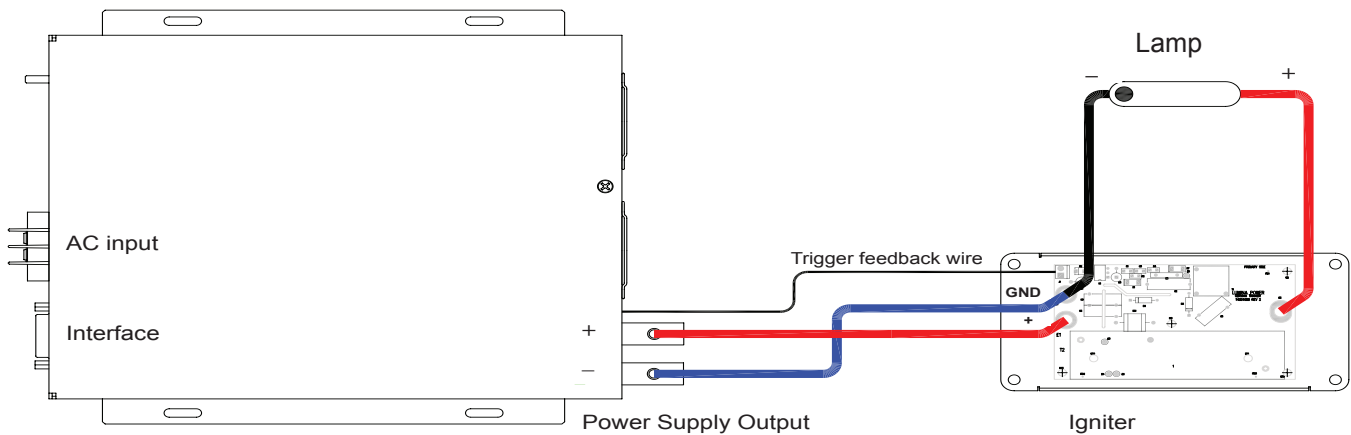

Figure 3 (positive Ignition)

The Igniter output is a high voltage pulse of about 1us. that will rise in voltage until the lamp ignites. The ignition point of the many different models offered by the lamp manufacturers varies widely and can range from 15kV to as high as 40kV. During the life of the lamp, the ignition voltage continues to rise until at the end of the lamp's usable life the electrodes have deteriorated to a point where the lamp will not ignite. If the lamp fails to ignite the Igniter has the capability to output as much as 45kV before shutting down so care needs to be taken to wire the lamp correctly.

Here are some recommended wiring and installation precautions to ensure proper lamp ignition.

1. The Igniter should be mounted as close to the lamp housing as possible. The distance from the power supply to the igniter is less critical and can be determined by the max current and practical wire size. Refer to wire size charts page 5 High Voltage does not run through the wire from the power supply to the igniter so isolating these wires for high voltage is not necessary.
2. The maximum distance of wire between the igniter and the lamp should be as short as possible with a recommended maximum length of no more than 30cm (15cm is preferred).
3. The combination of high starting voltage and high running current in the wires between the igniter and the lamp make the layout very critical. Typically available high voltage wire with a

high enough dielectric rating to handle 45kV pulses are not offered in wire sizes suitable for the high operating currents required of short-arc lamps. Most connections between the igniter and the lamp are made using insulated wire with a breakdown voltage of 600 to 1000 volts. This wire when sized properly will easily handle the current but it needs to be isolated from grounded surfaces and any wires that may provide a path to ground.

Keep this wire at least 25mm away from grounded surfaces and do not bundle this wire with other wires. Use plastic standoffs or flexible conduit if necessary. If your lamp does not start the first time you should thoroughly examine your igniter to lamp connections and make any necessary changes to enable the full energy of the igniter to get to the lamp.

4. Covering the igniter is not recommended. If necessary due to safety concerns the cover should not be metal. To avoid reducing the efficiency of the igniter any cover should be kept at least 25mm from the Igniter’s inductor on all sides. See also “Cooling the Igniter” below.

Trigger Wire

The power supply/igniter ships with a 60cm twisted pair wire called the trigger wire. This wire must be connected between the power supply and the igniter for proper operation. This feedback wire signals the power supply to temporarily shutdown for about 50us while the ignition pulse is discharged into the lamp. During this shutdown period any noise from the ignition pulse cannot return through the power supply potentially damaging the supply and other equipment near the power supply. This is an exclusive feature of the Lumina Power XLB/MLB family of power supplies

Cooling the igniter

The igniter used with all of the XLB power supplies is a series igniter. Once the lamp is lit the full output current from the power supply to the lamp travels through the large red inductor of the igniter. Proper mounting and cooling of the igniter is important to ensure reliable operation. Overheated Igniters are not covered under warranty.

The chart below offers some suggested cooling methods as a guide in mounting the igniter. In all cases the installation of the igniter in the exhaust of the lamp cooling system is not recommended and will damage the igniter. The maximum temperature of the inductor should not exceed 85°C

Model	Igniter	cooling (ambient air ≤ 30°C)
XLB-650	11001269	No fan required if open to air with no restrictions
XLB-1000	11001269	No fan required if open to air with no restrictions
XLB-1500	11001269	10cfm across inductor
XLB-2500	11001268	20cfm across inductor
XLB-3000	11001268	20cfm across inductor
XLB-5000	11001305	integral fan mounted on base, maintain 1 clearance for fan intake.

“No legal responsibility is taken for the correctness of this information.”