



MAIMAN ELECTRONICS

TC1540

TEC controller

Datasheet & User Manual

Before powering on your device, read this manual thoroughly.

If you have any doubt or suggestion, please do not hesitate to contact us!

Your contact:



Schulz-Electronic GmbH
Dr.-Rudolf-Eberle-Straße 2
D-76534 Baden-Baden
Fon + 49.7223.9636.0
Fax + 49.7223.9636.90
vertrieb@schulz-electronic.de
www.schulz-electronic.de

Maiman Electronics

e-mail: info@maimanelectronics.com

web site: www.maimanelectronics.com

v1.4.2 – 2023

v1.4.2:

Supplemented paragraphs “Features”, “Digital control description”. Added paragraph “Standalone mode”.

Table of content

1. Features..... 4

2. Applications 4

3. Controls 4

4. Description 4

5. Package set..... 4

6. Overall dimensions and weight 4

7. Absolute maximum ratings 5

8. Recommended operating conditions 5

9. Power supply requirements 5

10. Electrical characteristics..... 6

11. Functional scheme 8

12. Pin and terminal functions 9

13. Analogue control description 12

14. How to get started 13

15. PID coefficients 14

16. Standalone mode 14

17. Cooling..... 14

18. Internal protections 14

19. Software 15

20. Digital control description 15

21. Digital control description (extended) 24

22. Mechanical dimensions..... 28

23. Warranty 28

1. Features

- Temperature stabilization range 0°C to 80°C
- Low current ripple $\leq 35\text{mA}$
- Integrated PID controller
- Adjustable TEC output current & voltage limit
- Standalone mode
- Working with NTC sensors 1k Ω /2,2k Ω /4,7k Ω /6,8k Ω /10k Ω /22k Ω /47k Ω

2. Applications

- Peltier module control

3. Controls

- External input
- Digital control by RS-232/UART/USB¹/RS-485/I2C

4. Description

TC1540 is a non isolated DC/DC. TEC produces low current ripples. Additional features include an adjustable TEC output current and voltage limit and full PID controller with the ability to set all the coefficients, providing optimal temperature regulation.

TC1540 can be controlled by analogue or digital signals.

TC1540 is housed in 37 × 58 mm package with aluminum base plate to aid thermal dissipation. TEC controller can be mounted on any thermal conductive surface enough to dissipate losses.

5. Package set

- TEC controller – 1 pcs
- 50 cm ribbon cable with one 6-pin connector – 1 pcs
- 50 cm ribbon cable with one 8-pin connector – 1 pcs
- 50 cm ribbon cable with one 14-pin connector – 1 pcs
- Datasheet & User Manual – 1 pcs

6. Overall dimensions and weight

The TEC controller has overall dimensions of 57.9 x 36.8 x 21 mm and a weight of 56 g.

¹ Option, USB as external adapter

7. Absolute maximum ratings

	MIN	MAX	UNIT
Vin+ to Vin-	-0.3	50	V
Operating temperature	-40	50	°C
Enable analogue control pin to GND	-0.3	5.5	V
TEC temperature set analogue control pin to GND	-0.3	4	V
RS-232 RXD to GND	-25	25	V
RS-232 TXD to GND	-13.2	13.2	V
UART RXD to GND	-0.3	5.5	V
UART TXD to GND	-0.3	5.5	V
RS-485	-0.3	5.5	V
RS-485	-0.3	5.5	V
I2C SDA	-0.3	5.5	V
I2C SCL	-0.3	5.5	V

Stresses beyond those listed under absolute maximum ratings may cause permanent damage to the device. These are stress ratings only, which do not imply functional operation of the device at these or any other conditions beyond those indicated under recommended operating conditions. Exposure to absolute-maximum-rated conditions for extended periods may affect device reliability.

8. Recommended operating conditions

	MIN	MAX	UNIT
Input voltage (V_{in})	12	48	V
Operating temperature	-10	40	°C
Enable analogue control pin to GND	0	5	V
TEC temperature set analogue control pin to GND	0	3	V
RS-232 RXD to GND	-12	12	V
RS-232 TXD to GND	-12	12	V
UART RXD to GND	0	5	V
UART TXD to GND	0	5	V
RS-485 A	0	5	V
RS-485 B	0	5	V
I2C SDA	0	3.3	V
I2C SCL	0	3.3	V

9. Power supply requirements

The TEC controller requires a DC power supply with an output voltage of at least 12V and no more than 48V. The power supply must be able to cover the TEC output power and losses. The power supply must provide line regulation $\pm 1\%$. Recommended power supply: Mean Well PSP-600-48.

10. Electrical characteristics

PARAMETER	TEST CONDITIONS	MIN	TYP	MAX	UNIT
OUTPUT					
Output voltage		0		±40	V
Output current		0		±15	A
Current ripple				35	mA
Temperature change range		0		80	°C

CONTROLS					
Enable pin low threshold				1	V
Enable pin high threshold		2.3			V
Interlock pin threshold				1	V
Interlock pin pull-up resistance			10		kΩ
TEC temperature set step	Set by digital		0.01		°C
TEC temperature set step	Set by analogue		0.01		°C
TEC temperature set accuracy	Set by digital		1		%
TEC temperature set accuracy	Set by analogue		2		%
TEC temperature set calibration		-5		+5	%
TEC temperature monitor voltage	From 80°C to 0°C, B25/100=3435, NTC 1K	0.101		1.750	V
TEC temperature monitor voltage	From 80°C to 0°C, B25/100=3435, all NTC except 1K	0.127		2.188	V
TEC temperature monitor voltage	From 80°C to 0°C, B25/100=4000, NTC 1K	0.075		2.082	V
TEC temperature monitor voltage	From 80°C to 0°C, B25/100=4000, all NTC except 1K	0.094		2.602	V
TEC temperature monitor voltage	From 80°C to 0°C, B25/100=4455, NTC 1K	0.060		2.394	V
TEC temperature monitor voltage	From 80°C to 0°C, B25/100=4455, all NTC except 1K	0.074		2.992	V
1 kΩ NTC sensor resistance	Temperature from 80°C to 0°C, B25/100=4000	0.12		3.41	kΩ
2.2 kΩ NTC sensor resistance	Temperature from 80°C to 0°C, B25/100=4000	0.27		7.51	kΩ
4.7 kΩ NTC sensor resistance	Temperature from 80°C to 0°C, B25/100=4000	0.58		16.05	kΩ
6.8 kΩ NTC sensor resistance	Temperature from 80°C to 0°C, B25/100=4000	0.84		23.22	kΩ
10 kΩ NTC sensor resistance	Temperature from 80°C to 0°C, B25/100=4000	1.24		34.14	kΩ
22 kΩ NTC sensor resistance	Temperature from 80°C to 0°C, B25/100=4000	2.72		75.11	kΩ
47 kΩ NTC sensor resistance	Temperature from 80°C to 0°C, B25/100=4000	5.82		160.46	kΩ

INTERNAL MEASUREMENTS					
Internal measurements accuracy			2		%

INPUT					
Vin quiescent current		7	50	65	mA
Input capacitance			130		uF

POWER DISSIPATION					
Device losses	Calculated value			20	W

PCB THERMAL PROTECTION					
Over-temperature warning threshold temp			60		°C
Over-temperature warning hysteresis			2		°C
Over-temperature shut down threshold temp			80		°C
Over-temperature shut down hysteresis			22		°C

11.Functional scheme

Analogue interface

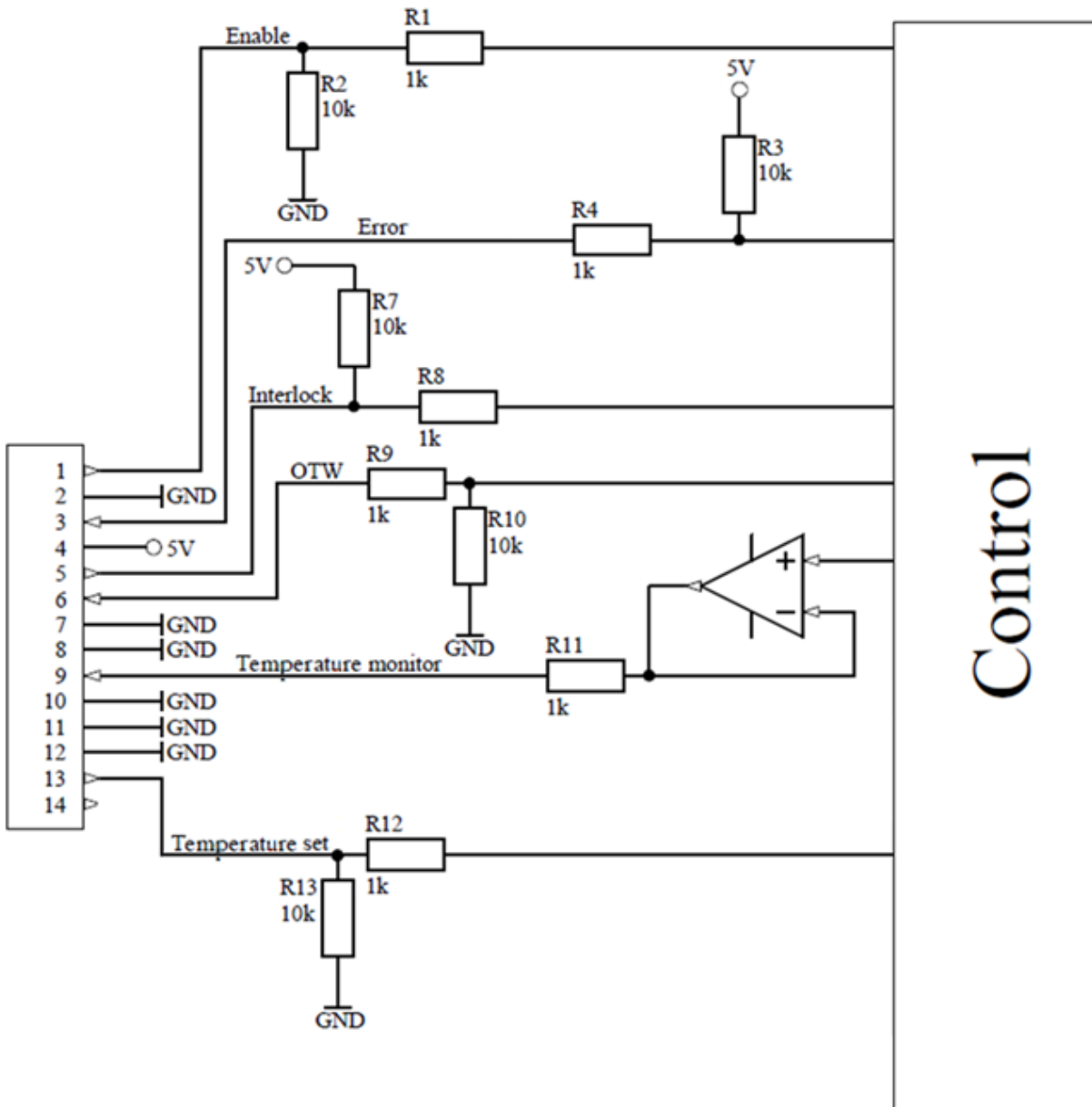

12. Pin and terminal functions

Please, note polarity!

**Never ground any lead of the output,
this may cause permanent damage to the device!**

Never use any grounded probes (e.g. from the oscilloscope) at the output!

Control pins are not isolated!

Terminals

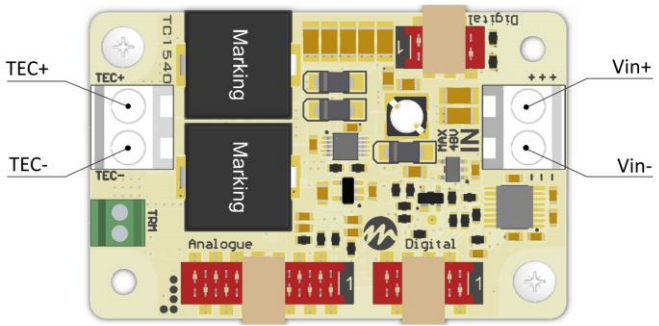
	Terminal	Description
 <p data-bbox="199 1142 798 1176">Please, pay attention to the markings!</p>	Vin+	Connect to the positive terminal of the power supply. Please, note polarity!
	Vin-	Connect to the negative terminal of the power supply. Please, note polarity!
	TEC+	Connect to the Peltier module positive input. Please note polarity! Grounding this terminal may cause permanent damage to the device.
	TEC-	Connect to the Peltier module negative input. Please note polarity! Grounding this terminal may cause permanent damage to the device.

Controls

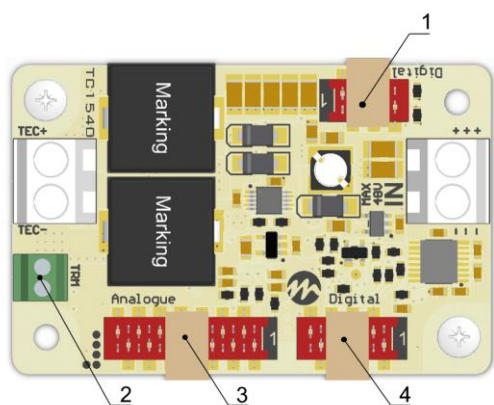
	№	Description
	1	I2C, RS-485 digital control connector
	2	Thermistor input
	3	Analogue control connector
	4	UART, RS-232 digital control connector

UART, RS-232 digital control connector

Würth WR-MM 690157000872 or TE Connectivity 215083-8

	Pin	Description
	1	UART RXD
	2	RS-232 RXD
	3	UART TXD
	4	RS-232 TXD
	5	+5V auxiliary (duplicates pin 4 of analogue control connector)
	6	Interlock (duplicates pin 5 of analogue control connector)
	7	Error (duplicates pin 3 of analogue control connector)
8	GND (connected to Vin- terminal)	

I2C, RS-485 digital control connector

Würth WR-MM 690157000672 or TE Connectivity 215083-6

	Pin	Description
	1	RS-485 A
	2	RS-485 B
	3	GND
	4	I2C SDA
	5	I2C SCL
6	GND	

Analogue control connector

Wurth WR-MM 6901 5700 14 72 or TE Connectivity 1-215083-4

PIN	I/O	Name	Description
1	I	Enable	HIGH = operates, LOW = stop. Internally pulled down.
2		GND	
3	O	Error	HIGH = fault, LOW = normal operation.
4		+5V	Auxiliary +5V power supply. Up to 200mA output current capability.
5	I	Interlock	Open = locked; Low = operates. Internally pulled up.
6	O	Over-temperature warning	High = $t^{\circ} > 60^{\circ}\text{C}$; Low = $t^{\circ} < 58^{\circ}\text{C}$. Internally pulled down.
7		GND	
8		GND	
9	O	TEC temperature monitor	See par. 13.4 <i>TEC temperature monitor</i> and par.10 <i>Electrical characteristics</i>
10		GND	
11		GND	
12		GND	
13	I	TEC temperature set	See par. 13.3 <i>TEC temperature set</i> and par.10 <i>Electrical characteristics</i>
14		Not connected	

13. Analogue control description

13.1. TEC Enable

The "Enable" contact is a logic input.

Apply high level to «*TEC Enable*» pin to start temperature stabilization. Apply low level to «*TEC Enable*» pin to stop temperature stabilization.

13.2. Error

The «Error» contact is logic output.

Error signal generates when there is overcurrent, overvoltage, short-circuit, TEC self-heat, device overheat, or when the temperature changes too quickly or changes in the wrong direction.

If an error occurs «Error» pin becomes high.

Error stops the TEC controller. To reset the error, restart the device.

13.3. TEC temperature set

The «TEC temperature set» pin is an analog input.

The «*TEC temperature set*» is intended for setting the desired temperature. Apply voltage to the «*TEC temperature set*» with respect to GND to set the desired temperature.

The specified voltage U [V] is related to the set temperature of stabilization t [° C] by the formula:

$$U(t) = K \exp\left(B_{\frac{25}{100}} \left(\frac{1}{t + 273.15} - \frac{1}{25 + 273.15}\right)\right)$$

$K=0.61$ for NTC 1 k Ω .

$K=0.762$ for NTC 2.2 k Ω , 4.7 k Ω , 6.8 k Ω , 10 k Ω , 22 k Ω , 47 k Ω .

$B_{\frac{25}{100}}$ – coefficient specified in the thermistor manufacturer's specifications.

For correct temperature measurement, you must specify the value of the connected NTC thermistor by digital control! By default, set NTC value is 10kOhm. After setting, the value will be saved in device memory and will work when used both digital and analogue control.

13.4. TEC temperature monitor

The «*TEC temperature monitor*» pin is an analog output and allows to track the temperature of the Peltier module.

Proportions described in paragraph 13.3 are valid for this Pin.

13.5. Over temperature warning

When the PCB temperature exceeds 60°C, the over-temperature warning will go high to indicate device is in danger of shutting down due to over-temperature condition. When the PCB temperature exceeds 80°C, the device will stop. The device can be restarted when the temperature drops to 58°C.

14. How to get started

Unpack the device. The new device is configured with the following values:

Parameter	Value
Peltier module current limit (set by digital)	15A
Peltier module voltage limit (set by digital)	40V
NTC nominal resistance	10kΩ
NTC B _{25/100} coefficient	3988

Connect the Peltier module and thermistor.

Please don't turn on TEC if you have not connected a thermistor (or dummy load) to the thermistor pins.

Connect the controls (analogue and/or digital).

Connect the power supply (note polarity).

14.1. Interlock

The device has interlock. This is pin 5 of the analog control connector. If you left this pin open, the device is in the locked state. This pin must be connected to any GND pin for normal operation.

The TEC can only be turned on with shorted Interlock.

You can also connect something like an emergency button to this pin.

By default at power up, the TEC is in the "allow interlock" state. Using digital control, you can set the TEC to the "deny interlock" state. At this case, the TEC will ignore interlock state and can operate with opened pin 5.

14.2. Change the current or voltage limit on the Peltier module

If it is necessary, the level of current or voltage limit on the Peltier module can be changed before connecting the Peltier module using digital control connection (see paragraph 19).

14.3. How to control by digital signals

Use the digital control connector. You can use UART, RS-232, RS-485, I2C. The USB-UART converter can be used (optional) to connect the device to computer.

See paragraphs 19-20.

14.4. How to control by analogue signals

Use the analogue control connector.

If you connect pin 1 to pin 4 (5V) before power up the device, the TEC will turn on.

See paragraph 13.

15. PID coefficients

The device allows you to set P, I and D coefficients independently of each other. The coefficients can be set in software or using digital commands.

The PID regulator works regardless of the control mode, both in analog and digital modes.

The default values are shown in the table.

P coefficient	I coefficient	D coefficient
100	100	100

Proportional coefficient sets direct response to the error signal. The value 100 is equal to a multiplier of 1.

Larger proportional gain result is larger changes in response to the error, and thus affects the speed at which the controller can respond to changes in the system. While a high proportional gain can cause a circuit to respond swiftly, too high a value can cause oscillations. Too low a value and the circuit cannot efficiently respond to changes in the system.

Integral control helps compensate for steady-state error.

Low values of the integral regulator lead to quick compensation, but can cause oscillations. Too large values lead to slow compensation. Zero value disables the integral regulator.

Derivative control attempts to reduce the overshoot and ringing potential from proportional and integral control. Derivative control slows the response of the circuit. High gain values cause the circuit to respond very slowly and can leave one susceptible to noise and high frequency oscillation. Zero value disables the derivative regulator.

Before fine-tuning the controller learn the theoretical foundations of PID controllers.

16. Standalone mode

The device can operate in standalone mode. This mode of operation assumes the absence of any control. This mode can be activated using digital control. When standalone mode is activated, all parameters are saved and cannot be changed. When the device is powered up the next time, the TEC will turn on automatically and operate according to the saved settings. **If you use Maiman BenchSoft to activate standalone mode, make sure that “Keep checkboxes” option is not selected!**

17. Cooling

The device produces up to 20W of losses. Thus the base plate has to be mounted on a thermal conduction surface to ensure proper operation and prevent an over-temperature shutdown. If the conduction cooling is not enough an additional cooling may be achieved by placing the device into the airflow of a fan.

18. Internal protections

The device provides several security features to ensure the safety of the Peltier module. In case of an over-current, over-voltage, short-circuit, Peltier module or the device over temperature condition, or when the temperature changes too quickly or changes in the wrong direction, the control logic disables the TEC .

The TEC current limit allows setting the maximum current and voltage safe for the Peltier module.

19. Software

We offer own software to control TEC. You can find it on maimanelectronics.com in the downloads section of the product page. Or contact us at info@maimanelectronics.com.

20. Digital control description

When the input voltage applied, the TEC is always in "analogue parameters set, external enable and allowing interlock" state. Any other state should be set any time after powering the TEC if needed.

20.1. UART, RS-232 protocol description

Default serial port settings:

Baud rate	Data bits	Stop bits	Parity	Flow control
115200	8	1	none	none

Data exchange between the device and the PC is only initiated by the PC. **All commands are sent in plain text format. All commands in text-plain mode should be in ASCII.** All commands are sent with prefix. Number of command follows the prefix without any symbols. If there is the value after the command they separates with "space" symbol. The command ends with "carriage return" symbol.

The format of the command to set the value (P-type):

Number of byte	Value	Comment
1	P (50h)	Set prefix
2-5	Number of the parameter	Hex-number of the parameter. For example, 0100h
6	'space' symbol (20h)	
7-10	New value of the parameter	Hex-value of the parameter. For example, 0000h
11	'return carriage' symbol<CR> (0Dh)	End of the command

The device does not respond to P-type commands by default (see section "the protocol extension").

You can request the value of parameter by the J-type command. The device will return a value of requested parameter.

The format of the command to get the value (J-type):

Number of byte	Value	Comment
1	J (4Ah)	Request prefix
2-5	Number of the parameter	Hex-number of the parameter. For example, 0100h
6	'return carriage' symbol<CR> (0Dh)	End of the command

The format of the response:

Number of byte	Value	Comment
1	K (4Bh)	Response prefix
2-5	Number of the parameter	Hex-number of the requested parameter
6	'space' symbol (20h)	
7-10	Returned value of the parameter	Hex-value of the parameter
11	'return carriage' symbol<CR> (0Dh)	End of the command

If the device could not recognize a command, it returns an error message with error code.

The format and codes of errors

Error (returned command)	Reasons (one or few)
E0000	1) Internal buffer of device is overflowed. 2) Cannot find <CR> (0x0D) or \and <LF> (0x0A). 3) Format of command is invalid.
E0001	1) Unknown command (it does not P- or J-type command). 2) The device failed to correctly interpret a command.
E0002	The CRC of received command (see section "Digital control description (extended)").
K0000 0000	Request or set the parameter that does not exist.

20.2. MODBUS protocol description

Default serial port settings:

Baud rate	Data bits	Stop bits	Parity	Flow control
115200	8	1	none	none

The driver has RS485 interface and can operate via MODBUS protocol. Data exchange between the source and the computer is carried out only at the initiative of the computer. To control the device, the MODBUS RTU protocol is used via the RS-485 communication line, with a maximum number of devices in the network equal to 32. The following commands are supported by the driver:

- 03h - multiple reading of memory registers
- 06h – single write to memory register
- 10h - multiple write to memory registers

All registers are 16 bits wide. Commands for multiple write/read work only with registers located in a row, if there is no such register when writing/reading, and then the driver will send an error. The read command works as follows: the driver sends the address of the first register, for example 0001h, and the number of requested registers, for example 0008h, thus, the response will receive register values from 1 to 8. With a write, the address of the first register, the number and the values themselves are also transmitted.

Commands format:

Multiple read query (Code = 0x03):

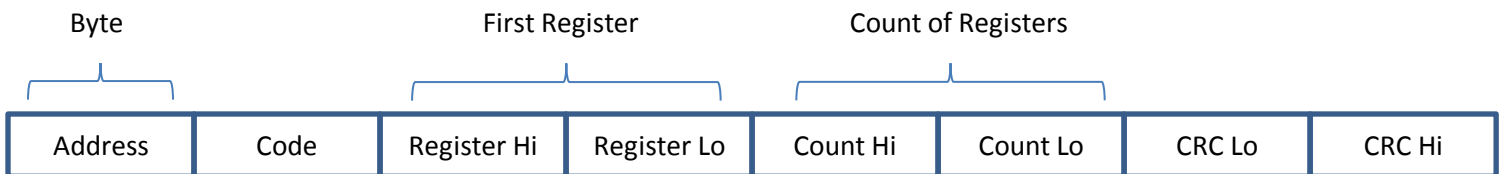

Multiple read answer (Code = 0x03):

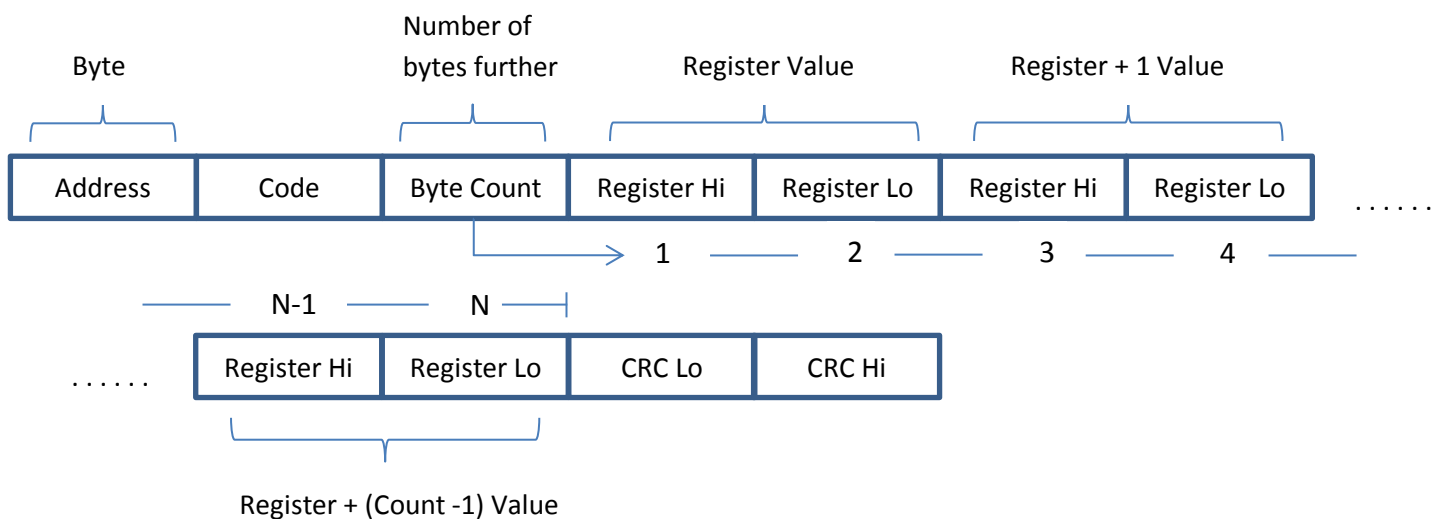

Single write query (Code = 0x06):



Single write answer (Code = 0x06):

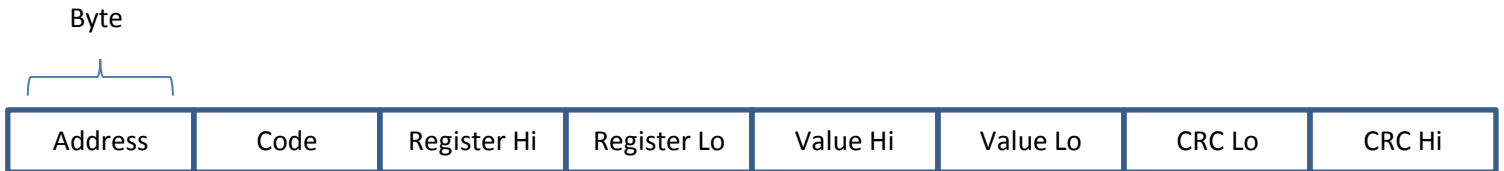

Multiple write query (Code = 0x10):

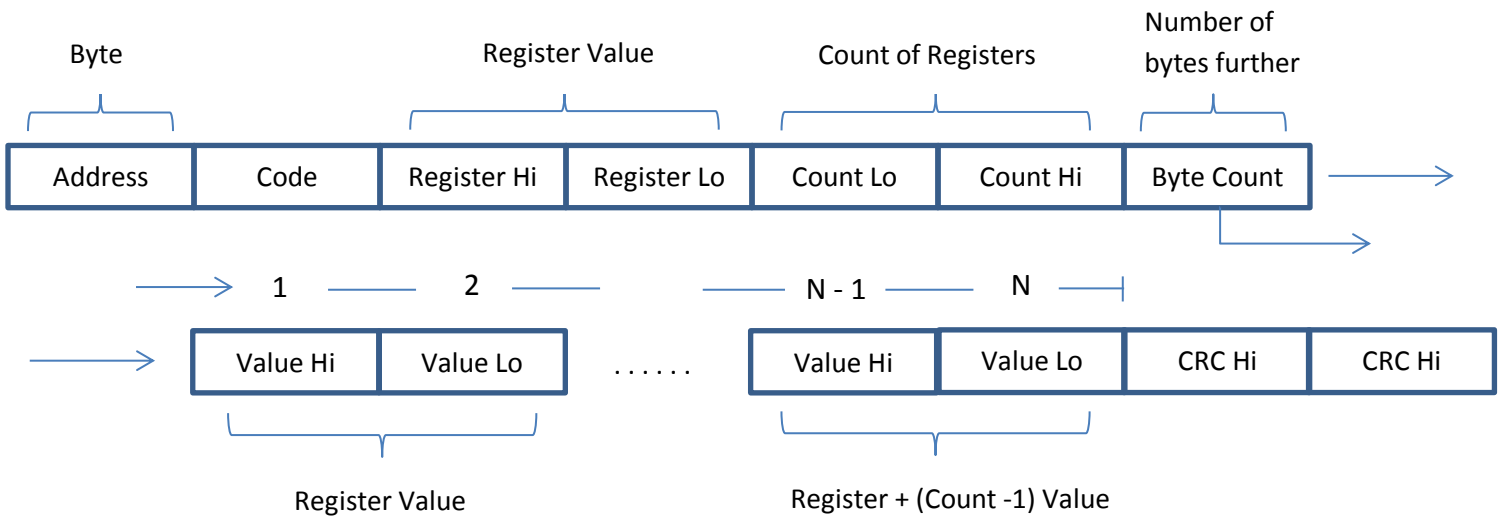

Multiple write answer (Code = 0x10):

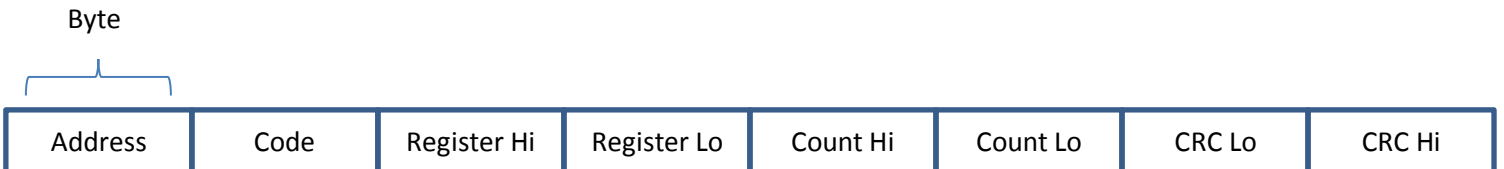

20.3. I2C protocol description

The default baud-rate is 100000. The address length is 7 bits.

Data exchange between the source and the computer is carried out only at the initiative of the computer. The list of commands may vary depending on the device model, up for new devices. It is possible to control up to 127 devices via I2C interface. The following commands are supported by the driver:

- 03h - multiple reading of memory registers
- 06h – single write to memory register

All registers are 16 bits wide. Commands for multiple write/read work only with registers located in a row, if there is no such register when writing/reading, and then the driver will send an error. The read command works as follows: the driver sends the address of the first register, for example 0001h, and the number of requested registers, for example 0008h, thus, the response will receive register values from 1 to 8. With a write, the address of the first register, the number and the values themselves are also transmitted.

Commands format:

Multiple read query (Code = 0x03):

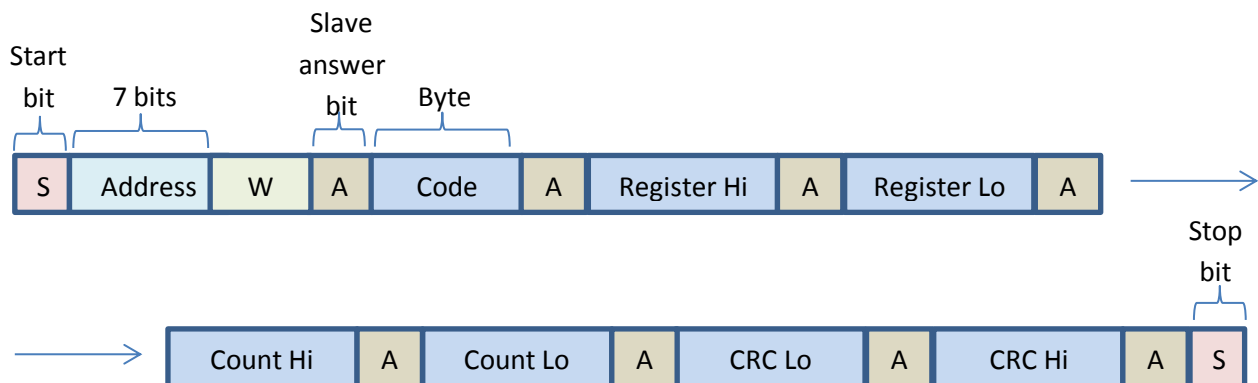

Multiple read answer (Code = 0x03):

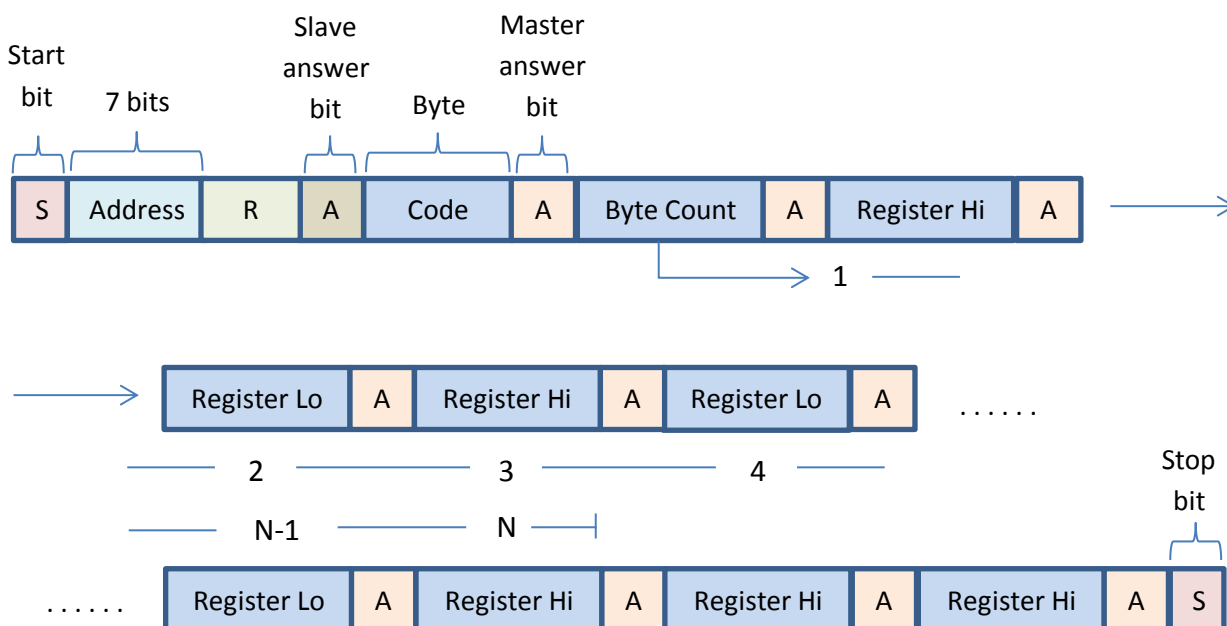

Single write (Code = 0x06):

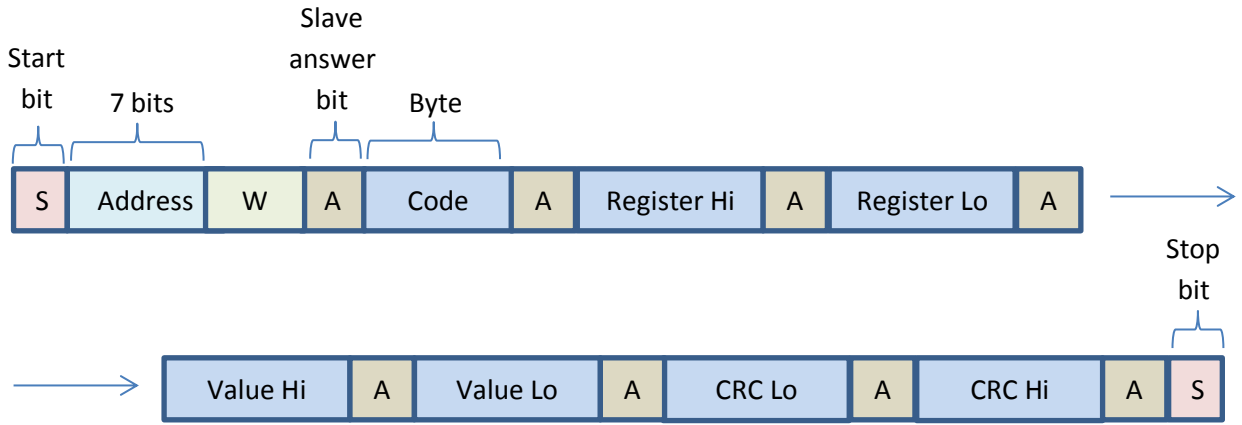

20.4. Available parameters and its description

Action		R/W	HEX-number of parameters		
			UART, RS-232	I2C, RS-485	
Serial number	Return the hex-value of the serial number	R	0701	0003	
Lock status (bit mask)	1 st bit	Interlock	R	0800	0005
	2 th bit	PCB overheat			
	3 th bit	Overcurrent			
	4 th bit	Overheat warning			
	5 th bit	TEC temperature acceleration			
	6 th bit	TEC temperature exceeds limits			
	7 th bit	TEC self-heat or reverse polarity			
	8 th bit	Short circuit			
RA-485 address²	Return the hex-value of the MODBUS address	R/W	0720	1000	
I2C address³	Return the hex-value of the I2C address	R/W	0730	2100	
TEC temperature (0.01°C)	Value	R/W	0A10	0070	
	Maximum	R/W	0A11	0071	
	Minimum	R/W	0A12	0072	
	Maximum limit	R	0A13	0073	
	Minimum limit	R	0A14	0074	
	Measured value	R	0A15	0075	
TEC current (0.1 A)	Measured value	R	0A16	0076	
	Limit	R/W	0A17	0077	
TEC voltage (0.1 V)	Measured value	R	0A18	0078	
	Limit	R/W	0A19	0079	
State of the TEC	Save parameter	0002h	W	0A1A	007A
	Clear memory	0004h			
	Start (Enable)	0008h			
	Stop (Disable)	0010h			
	Internal temperature set	0020h			
	External temperature set	0040h			

² Default – 0064h.

³ Default – 0064h.

State of the TEC	External Enable	0200h	W	0A1A	007A
	Internal Enable	0400h			
	Allow Interlock	1000h			
	Deny Interlock	2000h			
	Standalone Mode On	0060h			
	Standalone Mode Off	0080h			
State of the TEC (bit mask)	1 st bit	0 – Stopped; 1 – Started.	R	0A1A	007A
	2 nd bit	Temp. set: 0 – Ext.; 1 – Int.			
	4 th bit	Enable: 0 – Ext.; 1 – Int.			
	7 th bit	Interlock: 0 – Allow; 1 – Deny			
	8 th bit	Standalone mode: 0 – Off; 1 – On			
Temperature set calibration (0.01%)⁴	Value		R/W	0A1E	007E
NTC B_{25/100} (1 K)	Value		R/W	0A1F	007F
Nominal NTC Resistance (0.01 kOhm)⁵	1 kOhm	0064h	R/W	0A1D	007D
	2.2 kOhm	00DCh			
	4.7 kOhm	01D6h			
	6.8 kOhm	02A8h			
	10 kOhm	03E8h			
	22 kOhm	0898h			
	47 kOhm	125Ch			
P coefficient	Value		R/W	0A21	0091
I coefficient	Value		R/W	0A22	0092
D coefficient	Value		R/W	0A23	0093

⁴ Default – 100.00% (2710h), calibration range is from 95.00% (251Ch) to 105.00% (2904h).

⁵ Default – 10 kOhm (03E8h);

Examples (control via UART, RS-232)

1) For the TEC temperature value parameter, 0A10:

To request value, send the following command:

"J0A10" in text or "4a 30 41 31 30 0d" in hex.

Answer will be:

"4b 30 41 31 30 20 30 39 43 34 0d" in hex, "K0A10 09C4" in text, 09C4h > 2500 in dec > 25.00°C.

To set new value, 24.00°C (0960 in hex) for example, send the following command:

"P0A10 0960" in text, "50 30 41 31 30 20 30 39 36 30 0d" in hex.

2) For the state of the TEC, 0A1A:

To request value, send the following command:

"J0A1A" in text or "4a 30 41 31 41 0d" in hex.

Answer will be:

"4b 30 41 31 41 20 30 30 39 35 0d" in hex, "K0A1A 0094" in text, 0094h > 10010100 in bin > Device is powered on, stopped, internal temperature set, internal enable, denied Interlock.

To set new state, for example, allow Interlock, send the following command:

"P0A1A 1000" in text, "50 30 37 30 30 20 31 30 30 30 0d" in hex.

3) Errors:

If a command with the wrong parameter number was sent, answer will be "K0000 0000" ("4b 30 30 30 30 20 30 30 30 30 0d").

If a command with the wrong format was sent, answer will be an error "E0001" ("45 30 30 30 31 0d").

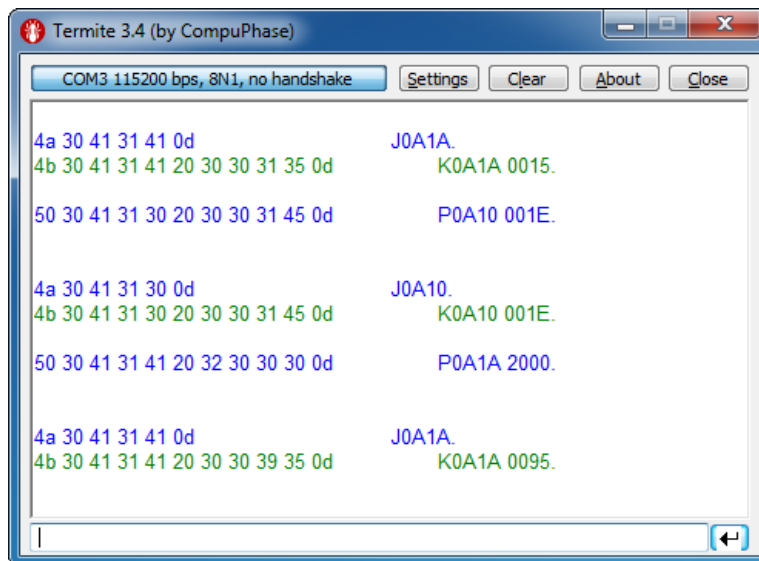

Screenshot from the Termite terminal with commands and answers

21. Digital control description (extended)

WARNING! *Extended protocol recommend for advanced users only. In addition, it might be use for integration of the device with other devices.*

The description of the UART protocol extension command

Action			R\W	HEX-number of parameters	
				UART, RS-232	RS-485
Information about the extended protocol	0 bit	1 – the device supports this option	R	0704	0080
	1st bit	Checksum (1 – on, 0 – off)			
	2nd bit	Return a new value for P-type commands (1 – on, 0 – off)			
	3-5 bits	Baud - rate 0 – 2400 1 – 9600 2 – 10417 3 – 19200 4 – 57600 5 – 115200 (default) 6 – 230400			
	6th bit	Data exchange mode (1 – binary, 0 –text-plain)			
Configuring of the extended protocol	On checksum (CS)	0002h ⁶	W	0704	0080
	Off checksum	0004h ⁶			
	Return a new value for P-type commands	0008h ⁶			
	Do not return answer for P-type commands	0010h ⁶			
	Set new baud-rate(baud) ⁷	0100h – 2400 0120h – 9600 0140h – 10417 0160h – 19200 0180h – 57600 01A0h – 115200 01C0h – 230400			
	Binary mode on ⁸	0200h			
	Text-plain mode on	0400h			

⁶ In binary mode the specified commands are ignored by the device.

⁷ Here are binary numbers.

⁸ For more information, see section “binary mode”.

The description of the MODBUS protocol extension command

Action			R\W	HEX-number of parameters	
				UART, RS-232	I2C, RS-485
Information about the extended protocol	3-5 bits	Baud - rate 0 – 2400 1 – 9600 2 – 10417 3 – 19200 4 – 57600 5 – 115200 (default) 6 – 230400	R	0705	0081
Configuring of the extended protocol	Set new baud-rate(baud) ⁹	0100h – 2400 0120h – 9600 0140h – 10417 0160h – 19200 0180h – 57600 01A0h – 115200 01C0h – 230400	W	0705	0081

⁹ Here are binary numbers.

Text-plain mode (UART, RS-232)

All commands in text-plain mode should be in ASCII.

WARNING! *If you enable the checksum it will change format of commands. After <CR> symbol you will be write 2 bytes of checksum and last byte will be <LF> (0Ah – “new line” symbol). Checksum is computed for all bytes of command before checksum bytes (including<CR> symbol).*

All answers of the device will also contain a checksum, including K-type and E-type answers. Checksum is computed by CRC-CCITT-8 algorithm. This is the main difference between the format of commands for the extended protocol and standard protocol.

The format of commands for enabled checksum

Number of byte	Value	Comment
1	P,J,K,E	Type of command
2-5	Number of parameter	Hex-number of value
6	‘space’ symbol (20h)	<i>(does not use for J and E-type commands)</i>
7-10	New value of the parameter	Hex-value of parameter <i>(does not use for J and E-type commands)</i>
11	‘return carriage’ symbol<CR> (0Dh)	End of value
12-13	Checksum	CRC checksum of the first 11 bytes <i>(for J and E-type commands checksum is computed for the first 6 bytes)</i> , including <CR> symbol.
14	‘new line’ symbol<LF> (0Ah)	End of command

Possible problems

1. The device waiting for symbol <LF>. If <LF> symbol does not received and buffer is overflowed, then all symbols after overload will be processed as a new command. The device returns an error. In this case, it is recommended to send the <LF> symbol. The device will generate an error and clear the buffer for the next command.
2. All symbols after the <LF> symbol will be processed as a new command.

Binary mode (UART, RS-232)

The binary mode has a significant difference. In this mode, data are exchanged in binary form. Length of any type of command is 8 bytes! In this mode, next options are always enable and you cannot disable it: return a new value of parameter for P-type commands and checksum. The format of binary mode commands is represented in table 8.

The format of binary mode commands

Number of byte	Value	Comment
1	Type of command	50h (P - ascii) – Set a new value of parameter 4Ah (J - ascii) – Get a value of parameter 4Bh (K - ascii) – Answer of the device 45h (E - ascii) – Error
2-3	Number of parameter	Hex-number of parameter
4-5	Value of parameter	Hex-value of parameter. This value is STRICTLY REQUIRED in the binary mode. If this value does not make sense, it will be returned as 0000 (K or E-type commands) or you should set it field to any value (for P or J-type commands).
6	‘return carriage’ symbol <CR> (0Dh)	End of value
7	Checksum	CRC checksum of the first 11 bytes (<i>for J and E-type commands checksum is computed for the first 6 bytes</i>), including <CR> symbol.
8	‘new line’ symbol <LF> (0Ah)	End of command

22. Mechanical dimensions

All dimensions are in millimeters.

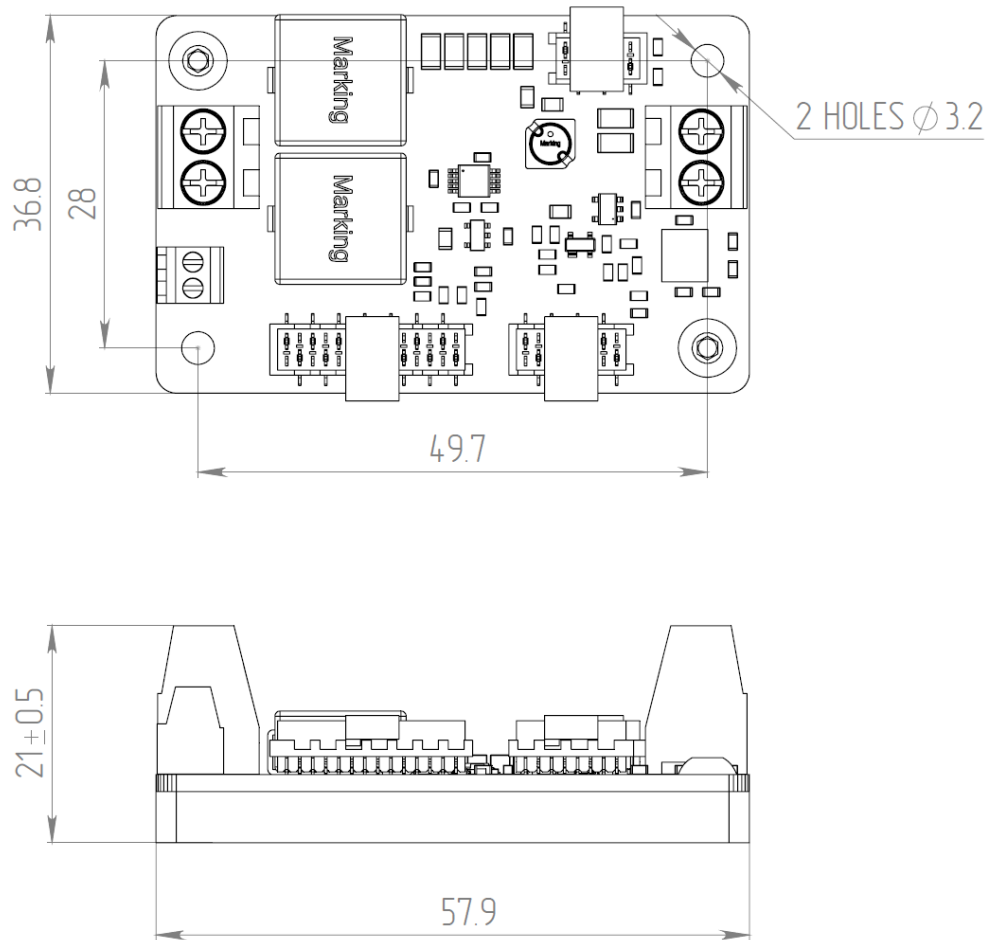

23. Warranty

In compliance with the provisions of Conditions limited warranty the Buyer has the right to guarantee during the one year period. The warranty period comes into effect from the shipping date.

The warranty only concerns products that are applied according requirements and for the applications specified in the manual for the product. If you want to use the products for other applications, contact us by e-mail: info@maimanelectronics.com. This warranty does not apply to damage due to incorrect use, abnormal use, or use in violation of product manual.

See the full warranty conditions on www.maimanelectronics.com/warranty.