

User Manual

LDP-1000/2000 Laser Diode Driver Power Supplies



Warning – Voltage Compliance Requirement

Each LDP is custom configured to deliver pulses of current into an array requiring a predefined compliance voltage.

Warning – Output Floating

The output of the LDP is floating and therefore, neither side of the laser diode should be connected to the same ground as signal ground (Program, Monitor).
DO NOT short output terminals together or to GND or chassis. High energy is stored on the DC buss capacitor.

Your contact:



Schulz Electronic
Professional Power Supplies

Schulz-Electronic GmbH
Dr.-Rudolf-Eberle-Straße 2
D-76534 Baden-Baden
Fon + 49.7223.9636.0
Fax + 49.7223.9636.90
vertrieb@schulz-electronic.de
www.schulz-electronic.de

1) Overview of the LDP System

Lumina Power's LDP power supplies are designed for CW or pulsed diode lasers in Quasi-CW applications.

The LDP consists of an AC/DC power supply and a High-Power Linear Regulator which provides user programmed current into a defined compliant voltage load at a selected power level and pulse width. These parameters must be defined before ordering the power supply.

The AC/DC power supply is a voltage controlled, current limited power source with an output capacitor bank which serves to store energy for the pulsed regulator.

The DC voltage that is provided to the capacitor bank is referred to as the Internal Buss Voltage and is user programmed at pin 10 located on the interface connector. In addition, it can be measured from the Positive output terminal with respect to GND at the interface port.

The load voltage can be measured across the output terminals with *differential scope probes*. Users should not ground the scope probes to either of the output terminals because they are connected to an internal circuit referenced to GND.

The AC/DC power supply is voltage programmed to put out 0V to a V maximum of approximately 10V higher than the expected/rated load voltage. Its internal current regulation delivers the average rated power to the load. In addition, the High-Power Linear Regulator can deliver any current and voltage up to a programmed 400A. The pulse-width and energy-per-pulse are determined by the internal and external cap banks. Nominal energy per pulse is about 20 Joules. See the Voltage-Current-Pulse Width chart.

In addition, the control system provides a user interface for the supply (see section 3 below) as well as various protection circuits for the laser diode.

2) Block Diagram

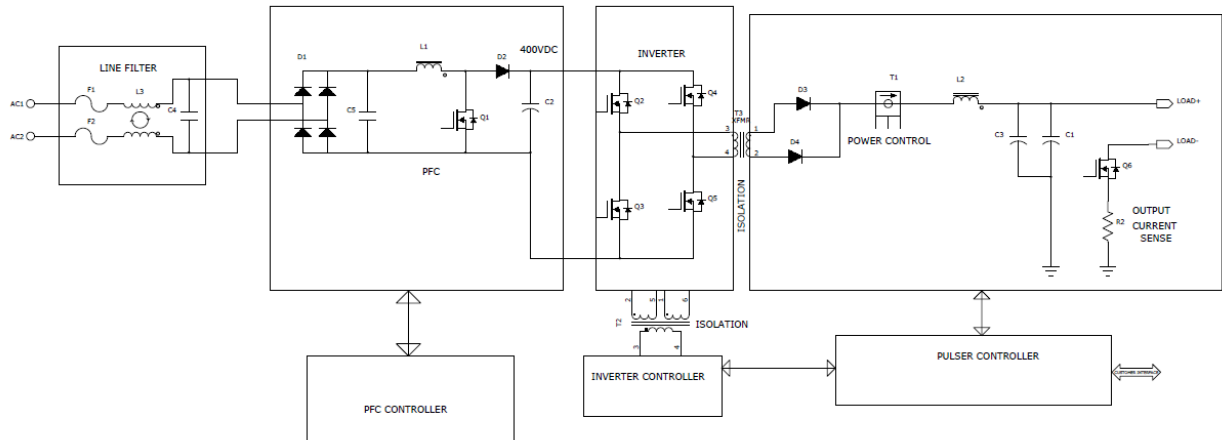

3) LDP-1000/2000-XX-YY SPECIFICATIONS

XX = $I_{out_{max}}$ YY = $V_{out_{max}}$

Model	P_{out}	I_{out}	Pulse Range	Input Voltage
LDP-1000-XX-YY	1000W	400A Peak 100A CW	50 μ s. to CW	100V to 240V AC
LDP-2000-XX-YY	2000W			100V to 240V AC

Specifications

Output

Power See Chart
200V max
Higher voltages available

Current 400A max

Auxiliary Outputs

+15V @ 100mA
-15V @ 100mA

CE/Safety Agency Approvals:

IEC 60601-1-2 4th Edition EMC
IEC 60601-1 3rd Edition Safety
IECEE CB SCHEME

Input

Voltage
LDP-1000 100 to 240VAC $\pm 10\%$, 50/60 H
LDP-2000 200 to 240VAC $\pm 10\%$, 50/60 Hz
Power Factor > .98

INTERFACE

Connector: 15 Pin "D" Sub Female
Current Program: 0-10V for 0-Max Current
Current Monitor: 0-10V for 0-Max Current
Voltage Monitor: 0-10V for 0-Max Voltage

PERFORMANCE

Rise/fall Time: 10 μ s for Vout <30V
Current Regulation: <0.5% of Maximum output current
Current Ripple: <0.5% of maximum output current
Current Overshoot: <1% of max. output current
Stable Output Range: 20 to 100% of rated of rated current

ENVIRONMENT

Operating Temp: 0 to 40°C
Storage: -20 to 85°C
Humidity: 0 to 90% non-condensing
Cooling: Forced air

4) Interface

Pin#	Pin Name	Function	Description
1	Enable (Input)	Hi = 5 to 15V = Run Low = < 0.3V = OFF	The Enable signal turns the power supply ON/OFF. When Enabled, the power supply allows output current to be delivered to the load as programmed at pin 7 with a logic level HIGH at pin 8.
2	Load-Match Fault	Hi = 15V = Good Low = 0V = Fault	Indicates Fault Mode when the load voltage is too low (mismatched) as compared to rated or programmed voltage. The system measures the differential voltage between the load and internal buss voltage at the end of each pulse and will shut the system down if it is more than 5V. If the Fault occurs, the V-Program needs to be re-adjusted downwards and the system needs to re-calibrated. This is an open collector with 10K Ω pull-up resistor. When the Fault occurs, reset the Enable signal to clear.
3	Interlock (Input)	Open = High = OFF. Connect to GND = Run	Used for external safety protection such as doors, shutters. The voltage at pin 3 must be less than 0.3V to run.
4, 9	GND		Interface return
5	Voltage Monitor (Output)	0-10V = 0-Full output rated voltage	Real time output voltage. Wave shape is similar to the Pulse signal. 1K Ω output impedance.
6	Output Current Monitor (Output)	0-10V = 0-Full output rated current	Real time output current. Wave shape is similar to Pulse signal. 1K Ω output impedance.
7	I-Program (Input)	0-10V => 0 to Full rated output Current	Controls the desired output current. 20K Ohm input impedance.

			<p>The power supply will not perform well when the I-Program is less than 20% of full rated current due to noise, linearity and offset.</p> <p>Due to internal power dissipation and the VI characteristics of laser diodes, current modulation is limited. Current modulation will result in lack of current regulation because the buss voltage will not increase enough for higher current. A large decrease in current regulation will result in a Load-Match fault because the differential voltage across the load and the buss will be excessive. See the description for pin 10, Vprog.</p>
8	Pulse Control (Input)	Hi = 5V to 15V = On Low = V < 0.3V = Off. Default/NC = Off.	<p>Enables the power supply to deliver current, as programmed on pin 7, to the load when applying a pulse signal of 5V to 15V on pin 8. Current Rise time <10us is typical.</p> <p>Voltage*Current proportionally dependent.</p>
10	V-Program (Input)	0 – 10V = 0 to Full buss voltage which should be 5V-10V higher than expected load voltage. Default (No Connect) = Full buss voltage.	<p>Sets the internal buss voltage to match load voltage. Set this voltage such that the internal buss voltage is 5 to 10V above the expected load voltage when in standby (Enabled but not pulsing).</p> <p>In operation, the power supply will regulate the buss voltage automatically for maximum efficiency by reducing the buss voltage.</p> <p>Excessive buss voltage relative to the load voltage will damage the series regulator at high current due to excessive internal dissipation.</p> <p>Also, extreme differential voltage between buss and load, about 30% of buss voltage, will result in the truncation of the pulse width.</p> <p>The buss voltage can be measured at the Positive output terminal with respect to GND at the Interface.</p>
11	Temperature (Output)	Hi = 15V = No Fault Low = Fault	<p>A Fault will shut off the power supply. The power supply can be reset after it cools off and when the Enable signal is toggled. This is an open collector with a 1.5KΩ pull-up.</p>
12	-15V @ 100mA (Output)		
13, 14	+15V @ 100mA (output)		
15	NC		

5) Interface Schematic

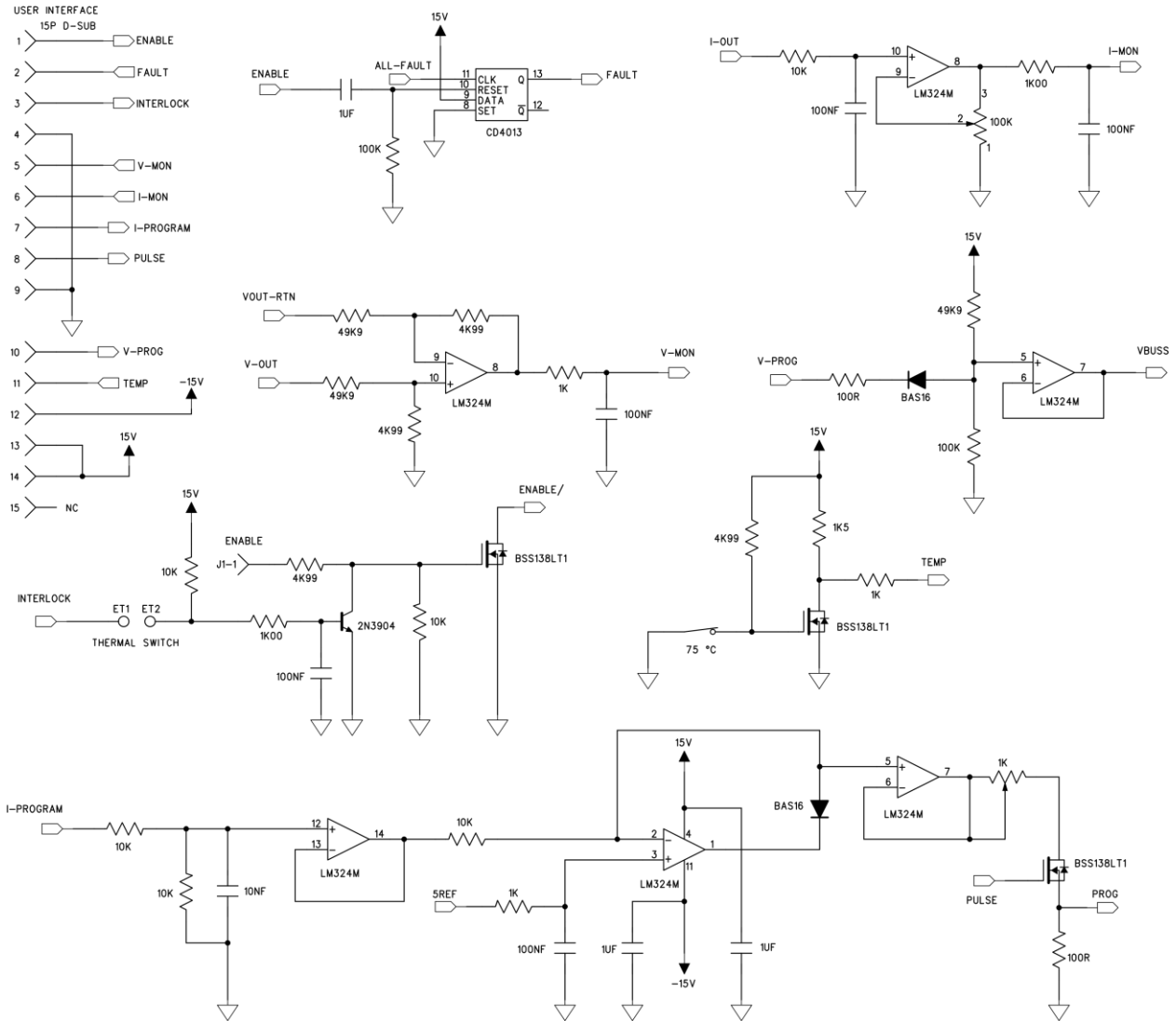

6) Pulsing Characteristics

The rise and fall times of the LDP's pulses are a compromise between speed and minimization of overshoot. Scope waveforms below show typical Rise time/Fall time and regulation.

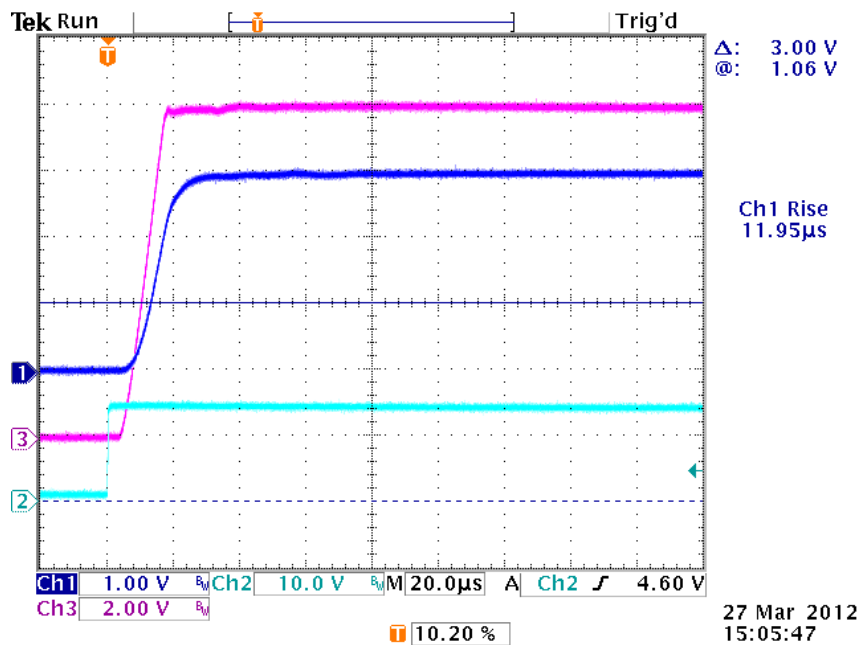

Channel: Output Current. 100Amp/V
Channel 2: Pulse Command Signal
Channel 3: Current Monitor

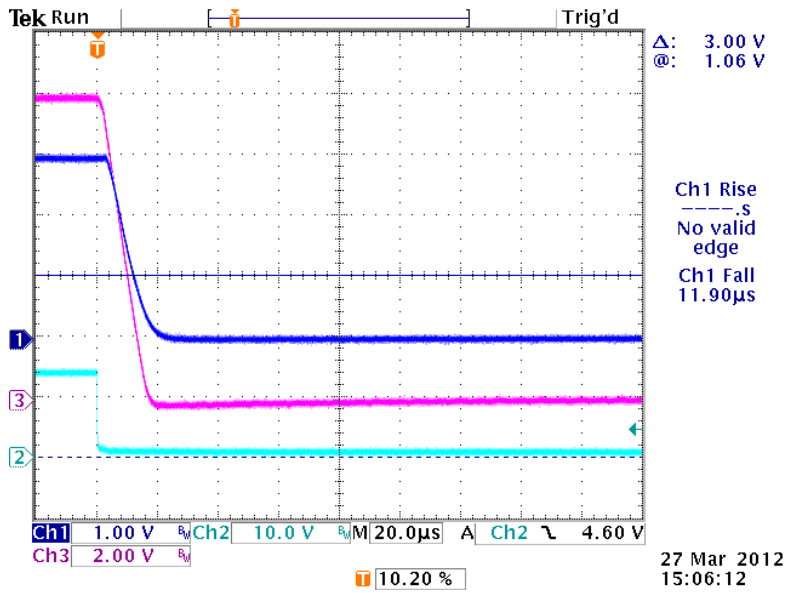

Channel 1: Output Current 100Amp/V
 Channel 2: Pulse Command Signal
 Channel 3: Current Monitor

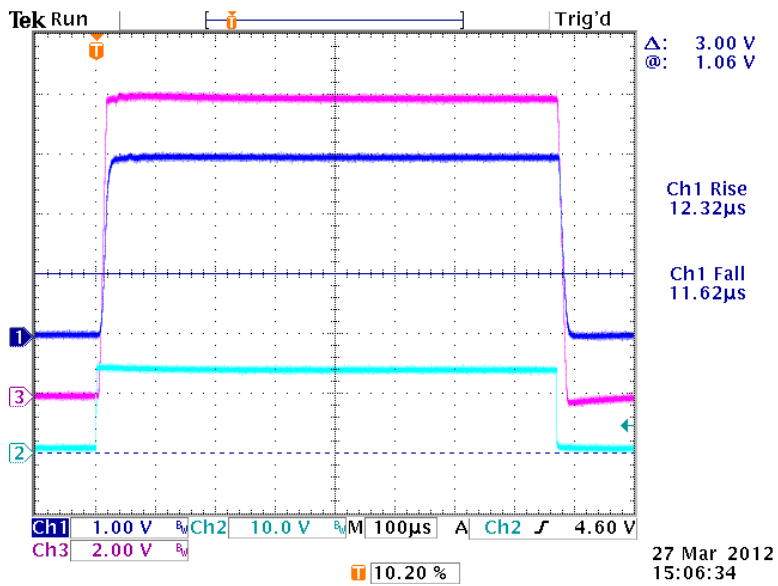

Channel 1: Output Current 100Amp/V
 Channel 2: Pulse Command Signal
 Channel 3: Current Monitor

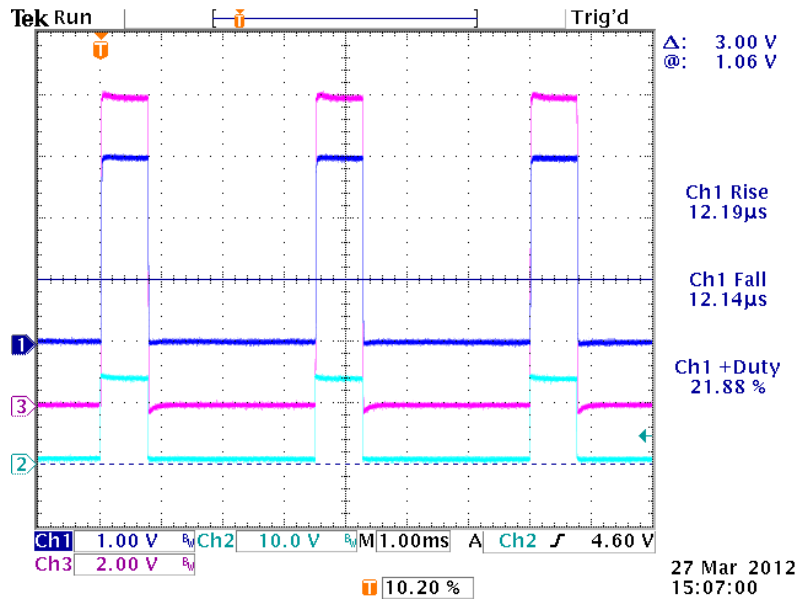

Channel 1: Output Current 100Amp/V
 Channel 2: Pulse Command Signal
 Channel 3: Current Monitor

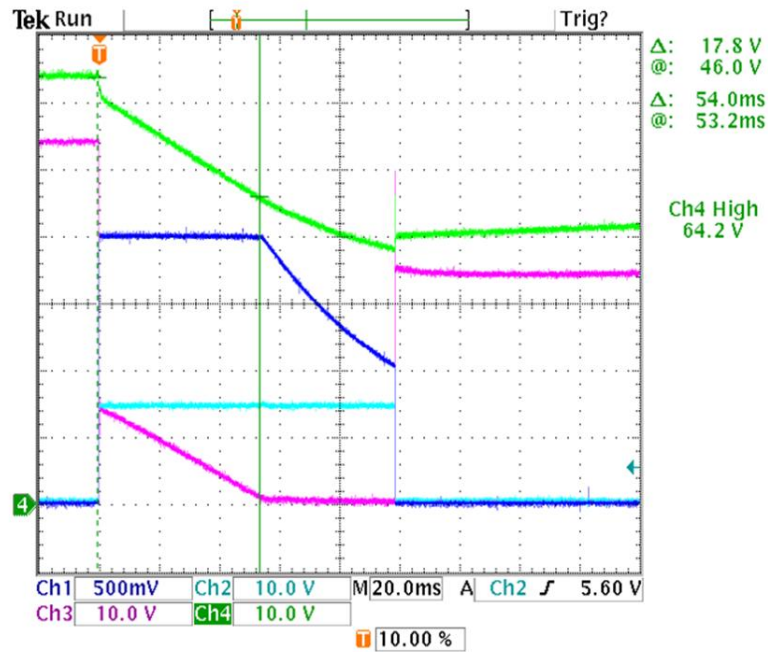

Channel 1: Output Current
 Channel 2: Pulse signal
 Channel 3: Voltage across the linear regulator
 Channel 4: DC Buss voltage.

7) LDP Theory of Operation

The LDP consists of two sections: A High Power Pulser and a programmable DC voltage-controller, a current limited internal power supply with a large output capacitor, including an optional external capacitor bank. The pulser is a linear current regulator with fast rise and fall times. This high-power linear regulator is typically a bank of high power MOSFETS mounted on an appropriate heat sink with temperature protection. The output of the DC power supply, which feeds the input to the Pulser, should be set at 5V to 10V higher than the expected load voltage when enabled and with no pulsing. However, when the LDP is running, the DC buss voltage will automatically adjust to have 1V to 2V at the end of each pulse in order to provide the correct pulsed current and maximum efficiency. This feature allows the DC buss to track the load voltage which changes with temperature and output current.

If the DC buss voltage is set too high resulting in too much DC buss voltage at the end of each pulse, ($V_{BUSS} > 5V$) the LDP will shut down as a result of a load mis-match.

If the DC buss is set too low, the pulsed current will be out-of-regulation near the end of the pulse, similar to channel 1 on the waveform below.

Laser diodes and silicon diodes have different I-V curves (Current-Voltage) with their V_f being proportional to current. Therefore, the LDP was designed for high efficiency and will track the load voltage and will simultaneously regulate the buss voltage to compensate for changes in load voltage due to variations in temperature and current.

If the output current or I_{prog} signal is changed to fast, the power supply will fail to regulate, resulting in shut down.

In the event of a rapid increase of the load diode's V_f , the power supply won't be able to increase the buss voltage instantaneously and thus will fail to regulate subsequent pulses. The length or number of poorly regulated pulses depends on the I-V characteristics of the load diodes, the load power and the rep rate.

In the event of a rapid decrease of diode V_f , the differential voltage between the buss and load voltage will be excessive and the LDP will shut down due to a load-mismatch.

Also note that the **control system** provides a 15-pin interface port to the supply and provides various protection circuits for the laser diode. See the interface pin descriptions in section 3.

8) System Set-Up

The best way to set up the system is to set the output current, I_{Prog} , at about mid-point, and then slowly increase V_{Prog} and observe the output current. It should start to increase once the buss voltage reaches the load voltage, but the current drops during the pulse.

Keep increasing the V_{Prog} until the current is just fully regulated during the whole pulse. Do this by monitoring the I-Monitor signal. Then stop the pulsing and record the buss voltage at this level. Finally, increase the buss voltage to about 7V to 10V higher for the full current.

Note that when the LDP is pulsing, even at very low current, the DC buss voltage is lower than in Standby mode because the LDP adjusts the buss voltage to be about 1 to 2V above the load voltage while in standby mode.

The LDP also allows users to set the DC buss voltage without shutting down when the current program, I_{Prog} , is less than 2.5V. At low current, the “Load-Match” protection circuit is disabled because the linear regulator does not dissipate that much power and thus it can tolerate a higher voltage drop. With a program voltage of 2.6V or higher, the protection circuit is active to protect its transistors from excessive dissipation, and will trip the “Load-Match” fault.

Warning: An excessive DC buss voltage, current and pulse width may damage the Pulser during the first pulse, before it reaches the end of the pulse to trip the “Load-Match” fault.

The LDP is the most efficient pulser on the market with its fast rise and fall times. The LDP utilizes a proprietary scheme to have a fast rise time even though the buss voltage is a few volts higher than the load voltage. This scheme gives the LDP the highest possible efficiency for a linear regulator and at the same time, eliminates or minimizes the inductance of the output cables. The LDP also tracks the diode forward voltage, V_f , which decreases as a function of increasing diode temperature.

The LDP can operate in pulsed mode or CW mode at any load voltage/current as long as the output power, voltage, or current does not exceed the maximum rating.

The optional external cap-bank is determined by the load voltage and energy per pulse. Refer to the Voltage-Current-Pulse Width chart.

9) Suffix “SR” Safety Relay Option

The LDN series Laser Diode Drivers can be specified to include the optional Dual Relay board and interface that allows the laser designer the ability to monitor the power supplies performance and signal the user if a fault occurs. This redundant safety feature complies with the ISO-DIN 13849-1-2008 safety standard at the highest level designated as E, and can be used to eliminate the costly safety shutter in many laser systems.

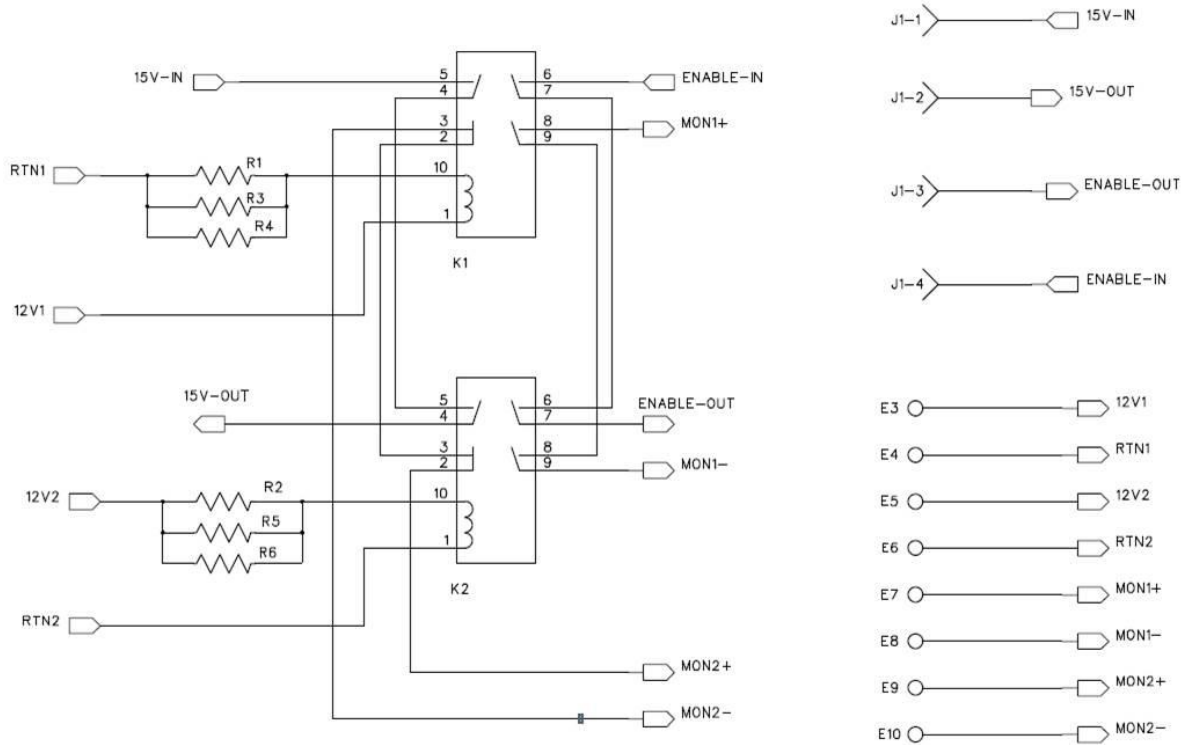

Relay K1 & K2 are 2 identical relays in series to control the VCC and Enable signals of the power supply. Both signals have to be active for the power supply to run. When both relays are energized, all contacts will be directed to the energized positions. There are also 2 monitor signals for these relays to ensure that they are working properly. One is normally closed and one is normally open. If the power supply is functioning correctly and the relays are energized, the Normally Closed will be open and the Normally Open will be closed. This indicates the relays are good and the power supply will operate normally. Both relays are forcibly latched and thus if one contact is stuck, the other contacts will be forced to the position of the faulty contact. If one or both relays are faulty and stuck Closed or Open, either the Normally Closed will not open or the Normally Open will not close. The host system should use these monitor signals to determine if the relays are good or bad. The timing required when using the SR option allows time to ensure the relays have actuated before applying the Enable and Pulse Input signals. The Enable signal must be low before the relay is energized. The I_{prog} signal on pin 7 can be changed at any time.

10) **Normalized Voltage-Current-Pulse Width Chart with nominal 20 Joules stored energy**

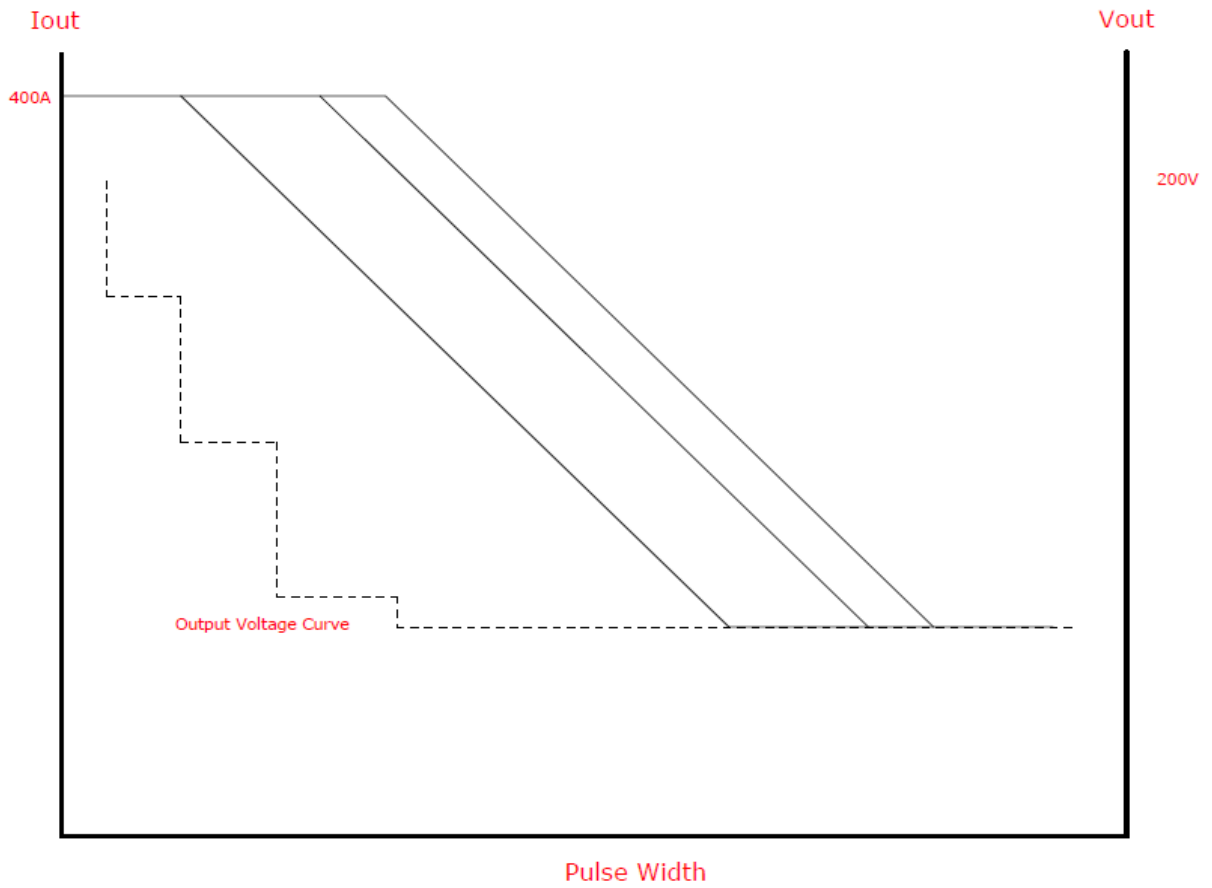

11) LDP Outline Drawing

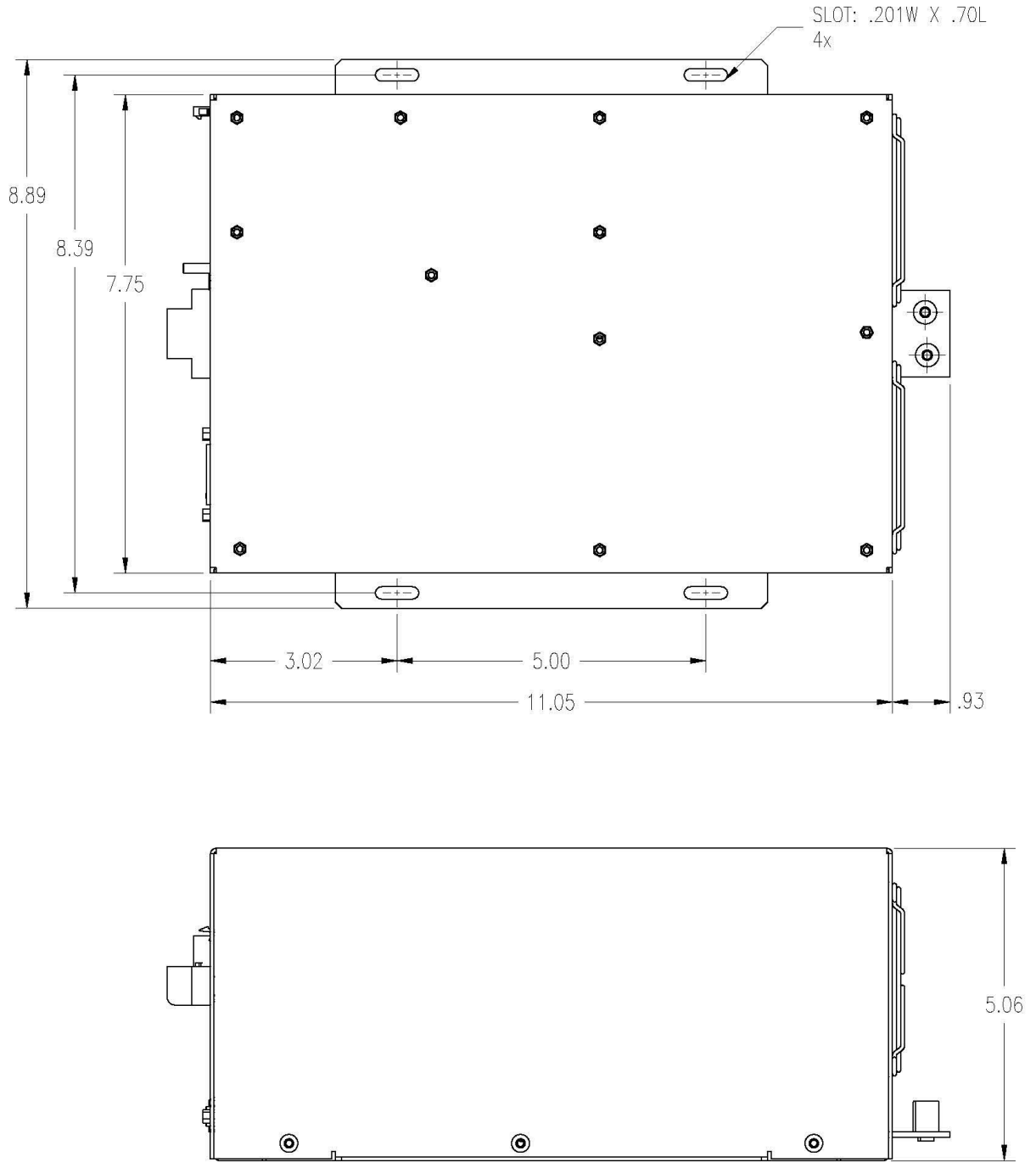

Your contact:



The image shows a contact card for Schulz-Electronic GmbH. On the left, there are two 3D geometric shapes: a blue pyramid and an orange pyramid. The logo consists of a blue triangle above the word "Schulz" in blue and "Electronic" in orange, with the tagline "Professional Power Supplies" in small blue text below. To the right of the logo, the company name and contact details are listed in a sans-serif font.

Schulz-Electronic GmbH
Dr.-Rudolf-Eberle-Straße 2
D-76534 Baden-Baden
Fon + 49.7223.9636.0
Fax + 49.7223.9636.90
vertrieb@schulz-electronic.de
www.schulz-electronic.de