

LDN Series Laser Diode Drivers



The New LDN series laser diode drivers are the second generation of precision CW/Pulsed diode drivers offered by Lumina Power. Building on more than a decade of experience in laser diode driver technology the new LDN family incorporates the features of the LDD and LDY models. New upgrades include increased energy storage for better pulsed performance, newly designed magnetics for cooler operation, lower inrush current at start-up and availability of an optional Performance Level “E” laser safety feature.

Offered in 4 power levels from 600 to 2000 watts the LDN family of laser diode drivers offer laser designers the most advanced and proven power supply technology available.

Features

- **600 to 2000 Watts Output**
- **Output Currents to 100amps**
- **Compliance Voltages to 200V**
- **Performance Level E Safety**
- **Power Factor Correction**
- **Universal Input Voltage**
- **Auxiliary +15/-15, +5V**
- **Low Conducted Emissions**
- **RoHS Compliant**



Your distributor:



Schulz Electronic
Professional Power Supplies

Schulz-Electronic GmbH
Dr.-Rudolf-Eberle-Straße 2
D-76534 Baden-Baden
Fon + 49.7223.9636.0
Fax + 49.7223.9636.90
vertrieb@schulz-electronic.de
www.schulz-electronic.de

LDN Series Laser Diode Drivers

Available Models

Model	Poutmax	Ioutmax	Input Voltage	Size (L x W x H)
LDN-600-XX-YY*	600 Watts	100 amps	100-240VAC ± 10%	9.9" x 7.3" x 2.6" 25.1 x 18.5 x 6.6 cm
LDN-1000-XX-YY	1000 Watts			
LDN-1500-XX-YY	1500 Watts		200-240VAC ± 10%	
LDN-2000-XX-YY	2000 watts			
Maximum compliance voltage: 200V, * LDN-600 not available in all countries				

Specifications

NOTE: Lumina Power reserves the right to change the specifications of this product without notice.

INPUT

Voltage: See table above
 Power Factor: >.98
 Inrush current: Equal to Vin/10 ohms

INTERFACE

Connector: 15 Pin "D" Sub Female
 Current Program: 0-10V for 0-Max Current
 Current Monitor: 0-10V for 0-Max Current
 Voltage Monitor: 0-10V for 0-Max Voltage
 (Optional RS232 interface available)

PERFORMANCE

Rise Time: >25msec using Pin 1 Enable
 Pulse pin 8: 100 to 600usec.**
 Current Regulation: <0.5% of Maximum output current
 Current Ripple: <0.5% of maximum output current
 Current Overshoot: <1% of maximum output current

** Depending upon output voltage and current. Contact customer service for more information.

ENVIRONMENT

Operating Temp: 0 to 40°C
 Storage: -20 to 85°C
 Humidity: 0 to 90% non-condensing
 Cooling: Forced air

REGULATORY

UL60601-1 (medical) Emissions/Immunity: FCC 47 CFR Class A Emissions, EN55011:1998 Group 1 Class A Emissions, EN61000-3-2, EN61000-3-3, EN60601-1-2:2001
 NOTE: Testing to be done March 2014.

AUXILIARY OUTPUTS

+5V @ 100mA
 +15V @ 100mA
 -15V @ 100mA

LASER SAFETY (optional)

Performance Level "E"
 Compliance to ISO DIN 13849-1-2008 Standard



LDN Series Laser Diode Drivers

Standard Interface (15 pin D-sub, Female)

Pin #	Pin Name	Functional Voltage Level	Description
1	Enable (input) (note1)	High = RUN = +5V to +15V Low = OFF = 0V	The Enable function turns the output section of the power supply ON and OFF. When the power supply is enabled, current is delivered to load as programmed via Iprogram(+), Pin 7. Rise times resulting from Enable are approximately 25msec.
2	Crowbar Status (Output)	High = Crowbar ON = 0 Low = Crowbar OFF = +5V	The Crowbar Status reports the status of the shorting crowbar clamp across the output. The crowbar will short the output when the output is not ENABLED via Pin 1, or if the output is ENABLED via pin 1 but the control circuitry has detected a no- load condition or a voltage requirement on the output that exceeds the maximum voltage rating of the unit.
3	Interlock (Input)	Open = OFF Connect to GND = RUN	The Interlock function can be connected to external interlock switches such as door or overtemp switches.
4,9, 15	GND		Interface Return
5	Vout Monitor (output)	0-10V = 0-Voutmax (note 2)	The output voltage monitor.
6	Iout Monitor (output)	0-10V = 0-Ioutmax	The output current monitor.
7	Iprogram (input)	0-10V = 0-Ioutmax	The power supply output current is set by applying a 0-10V analog signal to Iprogram(+). Note: Accuracy will be compromised when operating below 30% of the maximum value
8	Pulse Control (input)	+5 TO 15V = On 0 Volts= Off Default = On PL option: Default= low=off	The output may be pulsed by applying a +5 to 15V signal to Pulse Control, pin 8. The amplitude of the output current pulse is determined by the current level programmed via Pin 7, Iprogram(+). Rise/fall times of 100 to 600µs are typical.
10	+5V (output)		Auxiliary 100mA
11	Over Temp Warning	TTL High = High Temp TTL Low = Temp Ok	When temperature of main heat sink exceeds 65 Deg C, Pin 11, the Over-Temp Warning, will go to a TTL High to indicate unit is in danger of shutting down due to over-temperature condition. When temperature of main heat sink exceeds 75 Deg C, unit will shut down.
12	-15V (output)		Auxiliary 100mA
13,14	+15V (output)		Auxiliary 100mA

Note: Upon application of AC input voltage output current will be 0 regardless of Pin 1 setting. Enable (or toggle) pin 1 to output current. If maximum compliance voltage is less than 10V, Vout Monitor (pin5) will read output voltage directly. If maximum compliance voltage is greater than 10V, then Vout Monitor will be scaled such that 0-10V = 0-Voutmax. Applying a program voltage to pin 7 greater than 10.5 volts will latch power supply. Output current will not exceed 105% of rating



LDN Series Laser Diode Drivers

Performance Level “E” Safety Standard

The new LDN series Laser Diode Drivers can be specified to include the optional Dual Relay board and interface that allows the laser designer the ability to monitor the power supplies performance and signal the user if a fault occurs. This feature by redundant, forcibly guided relay contacts, is made to comply with external machine peripherals up to the highest safety standards of IEC/EN 13849-1 or IEC/EN 62061 and can be used to replace manually operated safety shutters in some applications. When ordering or inquiring about this feature please refer to the “SR” option.

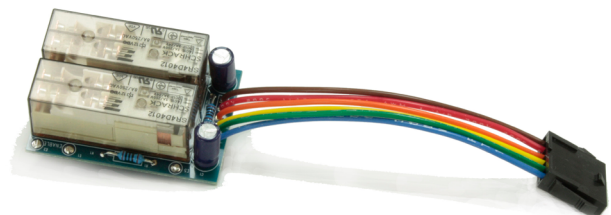
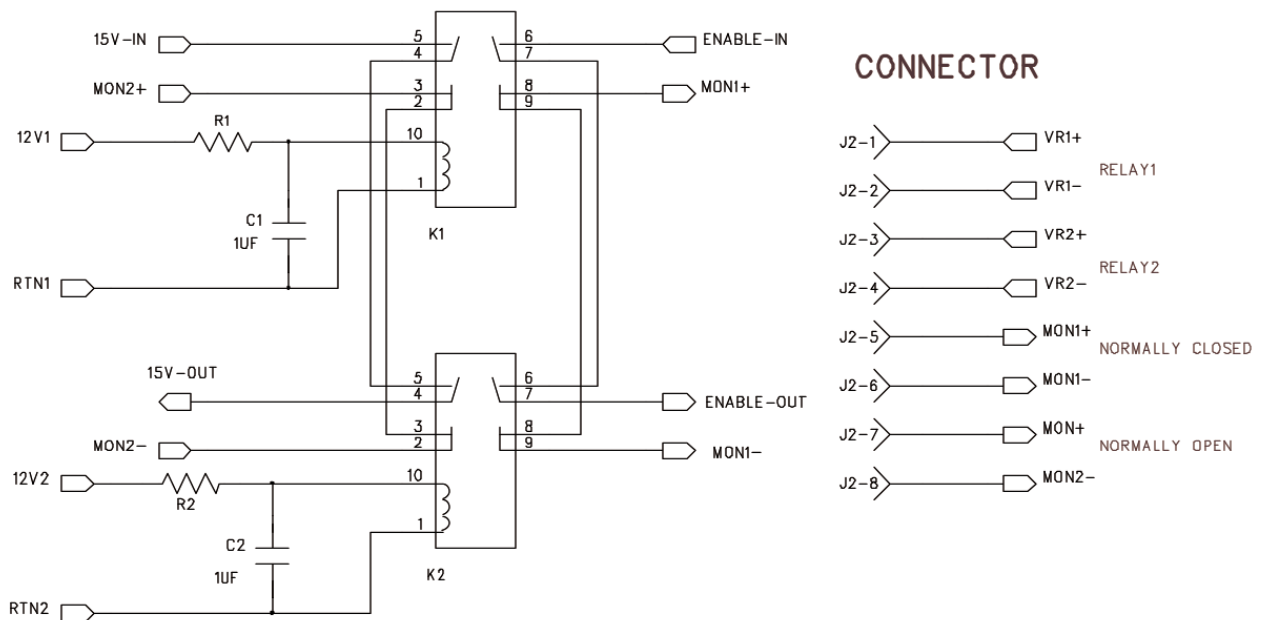

Optional Dual Safety Relay board
(factory installed)

LDN Series Laser Diode Drivers

LDN-600/1000/1500/2000
Outline Drawing

