



26 Ward Hill Ave., Bradford, MA 01835
Ph: 978-241-8260 Fx: 978-241-8262

CCPF-1500/2000-XX OPERATION MANUAL

Lumina P/N 02001055-01

- 1. Description of CCPF-1500/2000**
- 2. Explanation of Symbols**
- 3. Specifications**
- 4. Block Diagram**
- 5. Typical Applications**
- 6. Warnings**
- 7. Installation**
- 8. Service**

Your distributor:



1. Description of CCPF-1500/2000-XX

The CCPF-1500/2000-XX is a capacitor charging power supply designed for OEM laser manufacturers. The power supply provides up to 1500J/sec for line voltages below 140VAC and up to 2000J/sec for line voltages between 180VAC and 264VAC. The main power output provides a constant current to charge up a capacitor to the programmed value. An optional +24V is also available for auxiliary power.

The CCPF-1500/2000-XX can be configured for maximum output voltages up to 4000V. XX is the model designation which indicates the maximum output voltage. As an example, a CCPF-1500 configured for 1000V maximum output voltage is designated as a CCPF-1500-1P, where the P indicates a positive output. Positive output is the standard polarity.

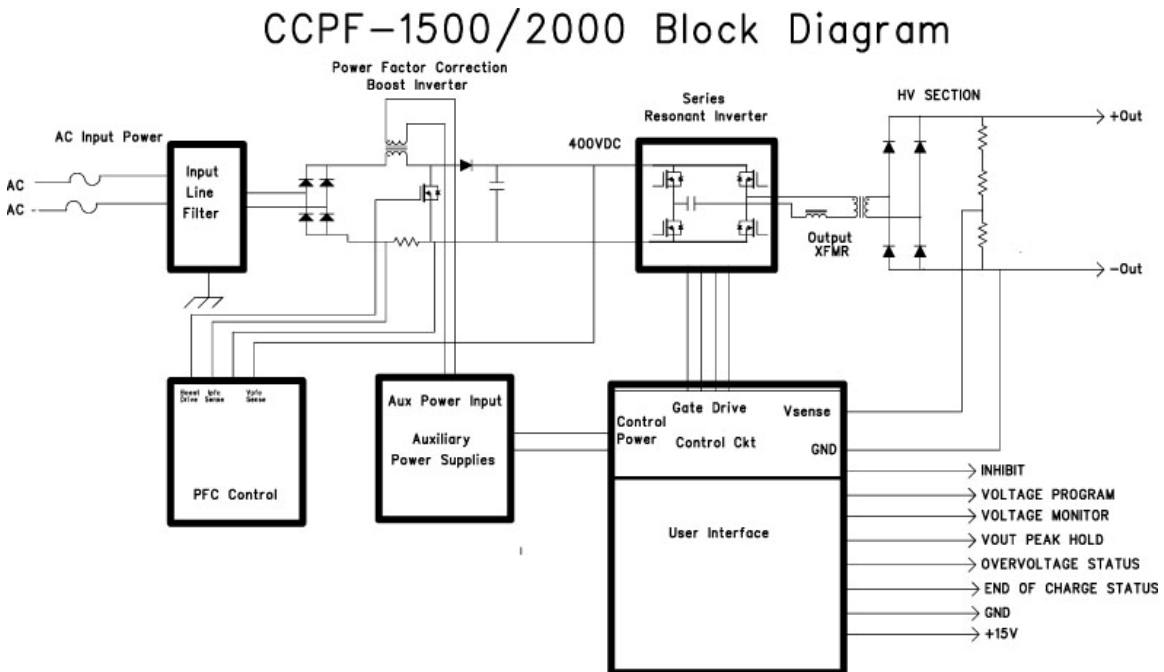

Figure 1.1 CCPF-1500/2000-XX Block Diagram

2. Explanation of Symbols



Hazard: This equipment produces high voltages which can be fatal. Only service personnel of Lumina Power, Inc. are qualified to service this equipment.



High Voltage Present. This power supply produces lethal high voltages. Only service personnel of Lumina Power, Inc., are qualified to service this equipment. Only qualified service personnel are permitted to install this power supply.

3. Specifications

CCPF-1500/2000-XX Specifications

XX = .2P to 4P (Units can be configured for $V_{out_{max}}$ from 200V to 4000V)

Input

Voltage: CCPF-1500: 100-240 VAC, 47Hz to 65Hz
CCPF-2000: 200-240 VAC, 47Hz to 65Hz
Current: CCPF-1500: 20A @100VAC, 7.8 @240VAC
CCPF-2000: 13.3A @200VAC, 11A @240VAC

Output

Power: CCPF-1500: 1500J/sec
CCPF-2000: 2000J/sec
Output Voltage: Configurable from 200V to 4kV.
Output Current: $2 * P_{out_{max}}/V_{out_{max}}$
Polarity: Positive
Efficiency: >75% at full output
Regulation: 0.5% @100Hz

Interface

Connector: 15 Pin "D"
Vout Program: 0-10V for 0- $V_{out_{max}}$
Vout Monitor: 0-10V for 0- $V_{out_{max}}$
 $V_{out_{peak}}$ Monitor: 0-10V for 0- $V_{out_{max}}$
Inhibit Control
End of Charge Status
Over-Temp Status

Environment

Operating Temp: 0 to 40 °C
Storage: -20 to 85 °C
Humidity: 0 to 90% non-condensing
Cooling: Forced air

Dimensions 12.5" x 4" x 5.75"
31.7cm x 10.1cm x 14.6cm

Regulatory

Leakage Current: <160uA
Isolation: 4000VAC/5700VDC
EMI: EN55011 Class A, Group 1 (Conducted and radiated)
Safety: EN60601.1, UL60601-1

4. Interface Information

CCPF-1500/2000-XX INTERFACE (15 Pin “D” Sub Connector Female)

<u>PIN #</u>	<u>TITLE/DESCRIPTION</u>
1	INHIBIT/FAULT RESET- (Input) This pin is the basic ON/OFF control pin for the power supply. Grounding pin 1 enables power supply operation if all faults are clear. Applying +15V to pin 1 prevents the inverter from operating. NOTE: In PFN applications, the power supply should be INHIBITED via Pin 1 during the period the PFN capacitor is discharged into the load. Noise from the discharge could cause improper operation if the power supply is not INHIBITED.
3	OVER-TEMP STATUS INDICATOR- (Output) 10V (+/- 0.5V) indication of over-temperature condition. This indicator is normally 0V, but will switch to 10V to warn of a pending over-temperature condition. If the internal temperature rises another 10 Deg C, the unit will automatically shut down.
4	VOLTAGE PROGRAM RETURN
5	VOLTAGE PROGRAM- (Input) Output is programmed externally with a 0 to +10V signal = 0 to $V_{out_{max}}$.
6	OVERVOLTAGE STATUS INDICATOR- (Output) Open collector output rated 30V, 100mA. Collector is tied internally to 4.02kohm pull-up resistor. If the load becomes open circuited, the power supply will detect the fault and shut down instantaneously, protecting itself and other equipment from over-voltage. If this occurs, pin 6 is pulled low. To restart, the INHIBIT/FAULT RESET function (Pin 1) must be set High.
7	V_{out} PEAK HOLD- (Output) Monitors output voltage with a peak hold circuit. The time constant of the peak hold circuit is approximately 5 seconds. 0 to +10V = 0 to $V_{out_{max}}$.
8	V_{out} MONITOR- (Output) Monitors output voltage. 0 to +10V = 0 to $V_{out_{max}}$.

CCPF-1500/2000-XX INTERFACE (continued)

<u>PIN #</u>	<u>TITLE/DESCRIPTION</u>
9	+15V (Output) Maximum output current is 100mA. This pin is internally tied to pins 11.
11	+15V (Output) Maximum output current is 100mA. This pin is internally tied to pins 9.
12	GND
13	END OF CHARGE STATUS INDICATOR- (Output) Open collector output rated 30V, 100mA. Collector is tied internally to 4.02kohm pull-up resistor. When the load capacitor reaches the programmed voltage, pin 13 is pulled low. Pin 13 will oscillate from high to low as the power supply replaces charge that is bled through the feedback network.
14	GND

CCPF-1500/2000-XX INTERFACE SCHEMATIC

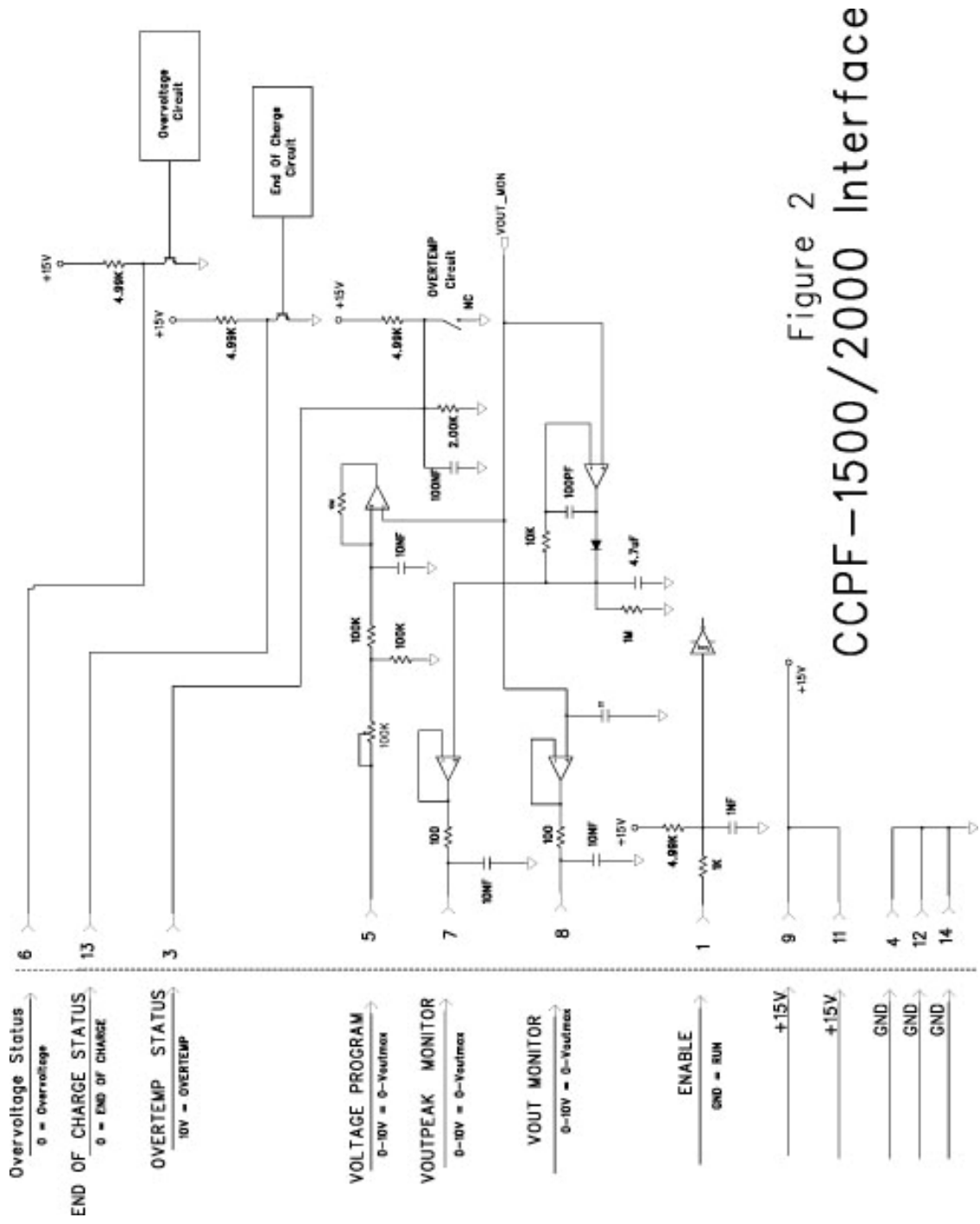
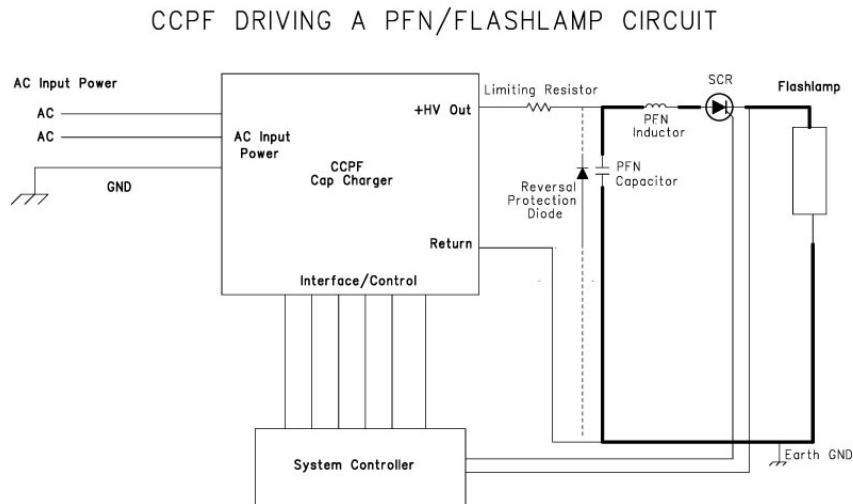

Figure 4.1 CCPF-1500/2000 Interface Schematic

5. Typical Applications

5.1 Using a CCPF with a pulse forming network (PFN)



The above block diagram shows a typical connection between a CCPF capacitor charging power supply and a well matched pulse forming network. In a typical operation, when the CCPF is ENABLED via Pin 1, the INHIBIT function, the CCPF will charge up the PFN capacitor to the programmed value and then transmit an END OF CHARGE signal to the user. Before discharging the load capacitor into the PFN, the CCPF should be disabled via the INHIBIT function. Once the PFN is completely discharged and the SCR has completely extinguished, the charging function can be ENABLED via the INHIBIT function and the CCPF will charge the capacitor again to the programmed value. PFN designers may choose to include a limiting resistor and a reversal protection diode to protect the power supply if there is any possibility of an arc in the PFN circuitry.

5.2 Using a CCPF with a square wave network (Reservoir Charging)

Square Wave Lamp Driver

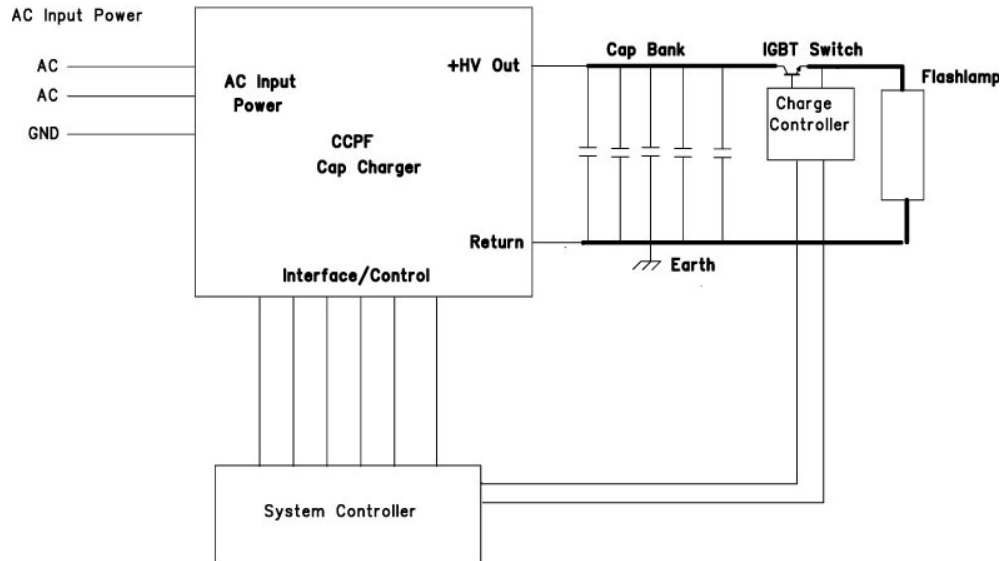

In this application, the power supply is **ENABLED** via the **INHIBIT** function and charges up the capacitor bank to the programmed voltage. The IGBT will deliver short, high current pulses to the flashlamp. The power supply is not **INHIBITED** during this process and continuously tops the capacitor bank.

6. WARNINGS



Warning:

Equipment is not suitable for use in presence of a flammable mixture with air or with oxygen or nitrous oxide.



Warning:

These power supplies are not provided with any isolation devices and shall only be used inside other medical equipment that has means to isolated its circuits electrically from the supply mains on all poles simultaneously.



Warning:

Equipment is not suitable for use in presence of a flammable Anesthetic mixture with air or with oxygen or nitrous oxide.

7. Installation

7.1 These power supplies are designed for and intended only for installation into laser systems using capacitor – flashlamp circuitry:

- Only qualified technicians or qualified assemblers may install these power supplies into their lasers.
- Only qualified Lumina Power personnel may service these power supplies.
- There are no user serviceable parts in this equipment.
- **Required wire and connectors:** Refer to the Figure 7.1 below for the locations of connections. Table 7-1 below shows required cables and connectors:

Connection	Description	Required Wire and Connectors
AC Input Power	2 Position terminal strip	At least 14AWG wire
AC Earth	10-32 GND stud	At least 14AWG wire
Interface	15 pin “D” female	15 pin “D” male
HV Output	MHV Female	MHV Male and coax cable rated for at least 150% of maximum rated output voltage of unit

Table 7-1 CC PF-1500/2000-XX Connections

- **Mounting of chassis:** Refer to Figure 7.1 below for location of four mounting holes in the power supply flanges.

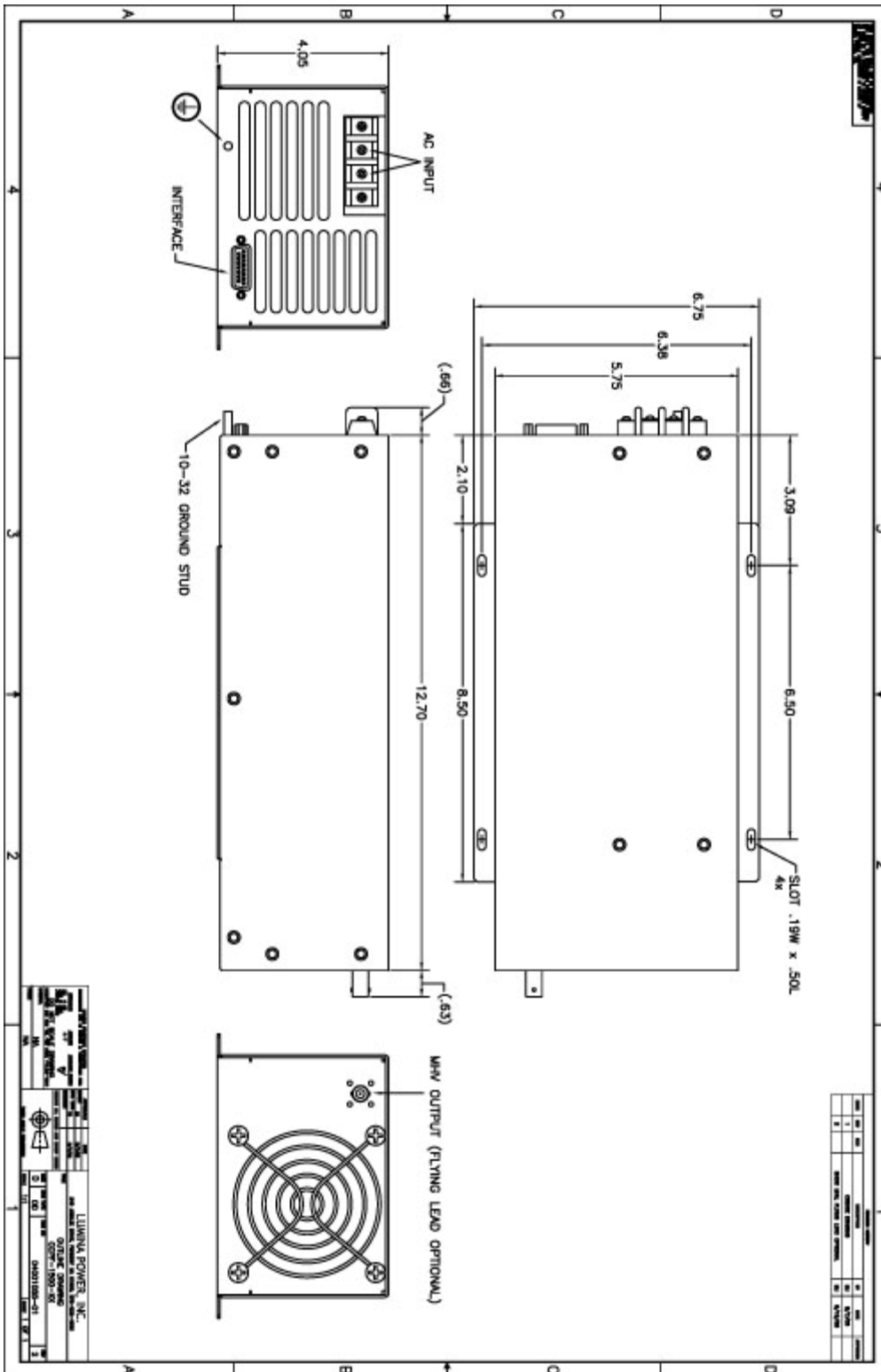

Figure 7.1 CCPF-1500/2000-XX Outline Drawing

- **Ventilation:** Unit is forced air cooled via an internal DC fan. A clearance of 2” should be maintained at either side of the power supply the fan end of the power supply as well as the grill side of the power supply. Hot air exits the grill side and should be routed out of the system.

8. SERVICE

This unit contains no user serviceable parts. Service and repair should be performed only by qualified personnel from Lumina Power, Inc. For more information contact

**Lumina Power, Inc.
 26 Ward Hill Ave.,
 Bradford, MA 01960
 Ph: 978-241-8260
 Fx: 978-241-8262**

ECO	Description	Doc Ctrl	Date	Approved
	Initial Release	M J		BO'B